

# Cap Tip

$\phi 9 \times 20$  type Taper  $\phi 7 \times 1/10$

キャップチップ material(材質) : CrCu(クローム銅)

Unit(単位):mm

## C-0920-R

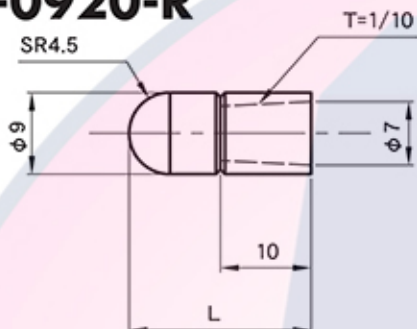

Model No. 型式	L 全長
C-0920-R	20
C-0925-R	25
C-0930-R	30

material(材質) : CrCu(クローム銅)

Unit(単位):mm

## C-0920-P

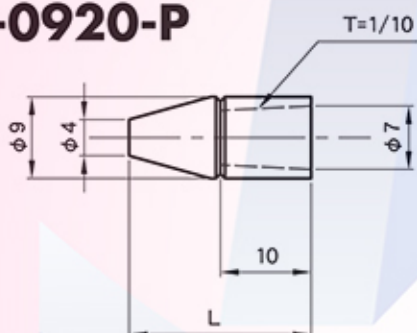

Model No. 型式	L 全長
C-0920-P	20
C-0925-P	25
C-0930-P	30

material(材質) : CrCu(クローム銅)

Unit(単位):mm

## C-0920-E

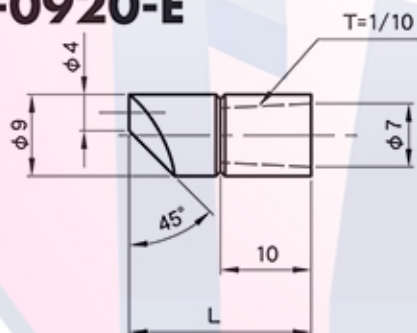

Model No. 型式	L 全長
C-0920-E	20
C-0925-E	25
C-0930-E	30

material(材質) : CrCu(クローム銅)

Unit(単位):mm

## C-0920-F

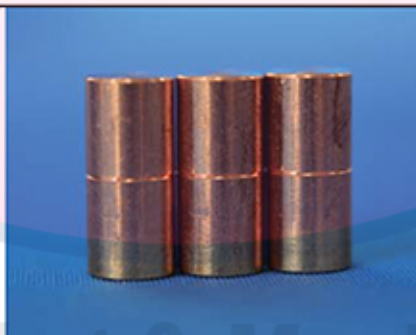
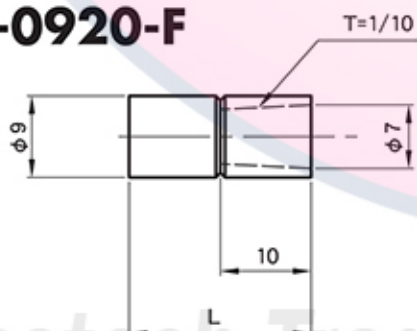

Model No. 型式	L 全長
C-0920-F	20
C-0925-F	25
C-0930-F	30

material(材質) : CrCu(クローム銅)

Mastech Trading & Machining co.,Ltd.

# Cap Tip

$\phi 12 \times 20$  type Taper  $\phi 10 \times 1/9.6$

キャップチップ material(材質) : CrCu(クローム銅)

Unit(単位):mm

## C-1220-D

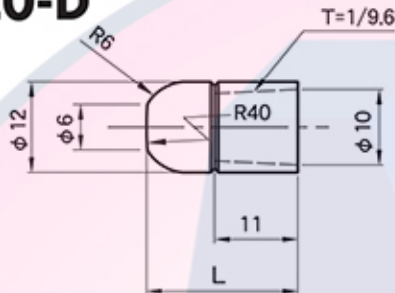

Model No. 型式	L 全長
C-1220-D	20
C-1225-D	25

material(材質) : CrCu(クローム銅)

Unit(単位):mm

## C-1220-R

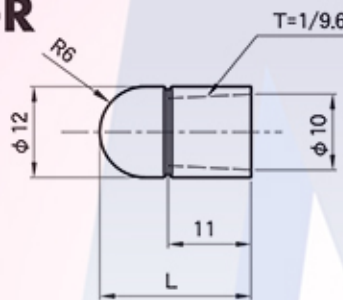

Model No. 型式	L 全長
C-1220-R	20
C-1225-R	25

material(材質) : CrCu(クローム銅)

Unit(単位):mm

## C-1220-P

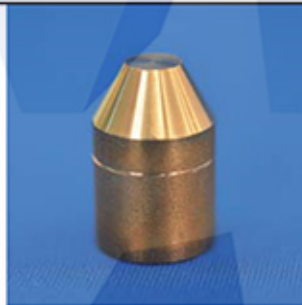
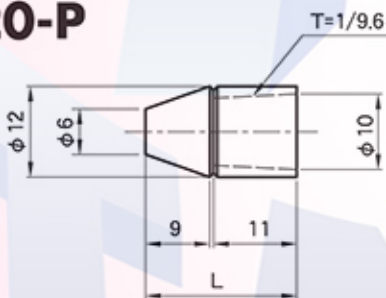

Model No. 型式	L 全長
C-1220-P	20
C-1225-P	25

material(材質) : CrCu(クローム銅)

Unit(単位):mm

## C-1220-E

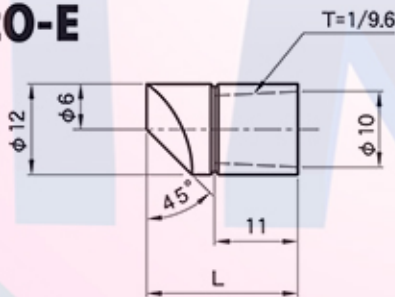

Model No. 型式	L 全長
C-1220-E	20
C-1225-E	25

material(材質) : CrCu(クローム銅)

Unit(単位):mm

## C-1220-F

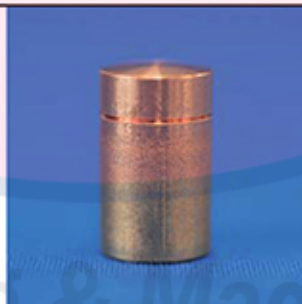
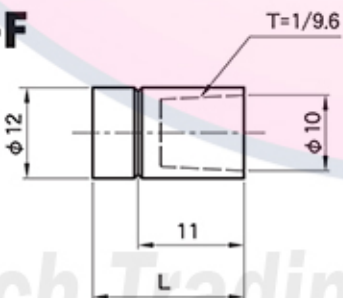

Model No. 型式	L 全長
C-1220-F	20
C-1225-F	25

material(材質) : CrCu(クローム銅)

Mastech Trading & Machining co.,Ltd.



## Cap Tip

 $\phi 13 \times 20$  type Taper  $\phi 10 \times 1/9.6$ 

キャップチップ material(材質): CrCu(クローム銅)

Unit(単位):mm

## T-CT-R-13×6A

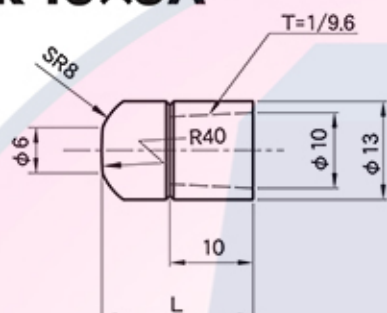

Model No. 型式	L 全長
T-CT-R-13×6A	20
T-CT-R-1323×6A	23
T-CT-R-1325×6A	25

material(材質): CrCu(クローム銅)

Unit(単位):mm

## T-CT-C-13×6A

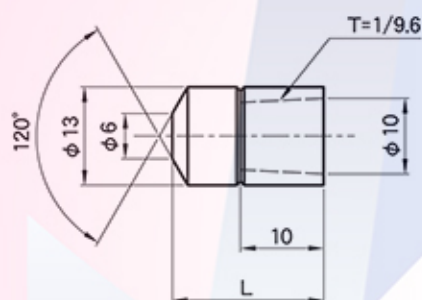

Model No. 型式	L 全長
T-CT-C-13×6A	20
T-CT-C-1323×6A	23
T-CT-C-1325×6A	25

material(材質): CrCu(クローム銅)

Unit(単位):mm

## T-CT-D-13×6A

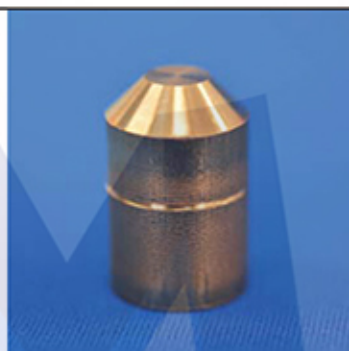
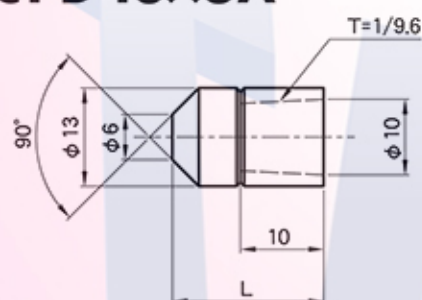

Model No. 型式	L 全長
T-CT-D-13×6A	20
T-CT-D-1323×6A	23
T-CT-D-1325×6A	25

material(材質): CrCu(クローム銅)

Unit(単位):mm

## T-CT-E-13×6A

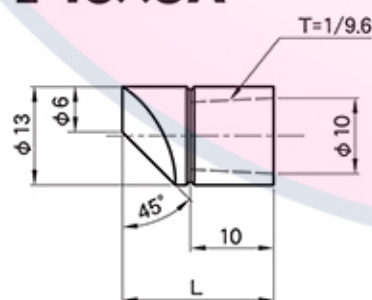

Model No. 型式	L 全長
T-CT-E-13×6A	20
T-CT-E-1323×6A	23
T-CT-E-1325×6A	25

material(材質): CrCu(クローム銅)

Mastech Trading &amp; Machining co.,ltd.

## Cap Tip

 $\phi 13 \times 20$  type Taper  $\phi 10 \times 1/9.6$ 

キャップチップ material(材質) : CrCu(クローム銅)

Unit(単位):mm

### T-CT-R-13×6.5DA



Model No. 型式	L 全長
T-CT-R-13×6.5DA	20
T-CT-R-1323×6.5DA	23
T-CT-R-1325×6.5DA	25

material(材質) : CrCu(クローム銅)

Unit(単位):mm

### T-CT-13×6.5RA



Model No. 型式	L 全長
T-CT-13×6.5RA	20
T-CT-1323×6.5RA	23
T-CT-1325×6.5RA	25

material(材質) : CrCu(クローム銅)

Unit(単位):mm

### T-CT-B×13A





Model No. 型式	L 全長
T-CT-B×13A	20
T-CT-B×1323A	23
T-CT-B×1325A	25

material(材質) : CrCu(クローム銅)

Unit(単位):mm

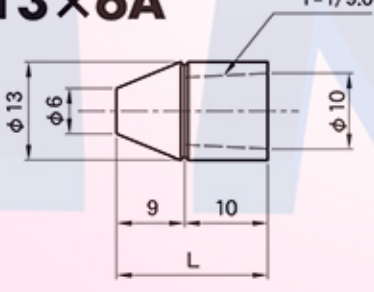
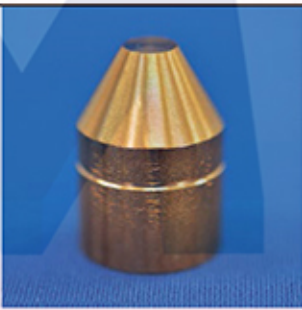
### T-CT-P-13×6A





Model No. 型式	L 全長
T-CT-P-13×6A	20
T-CT-P-1323×6A	23
T-CT-P-1325×6A	25

material(材質) : CrCu(クローム銅)

Unit(単位):mm

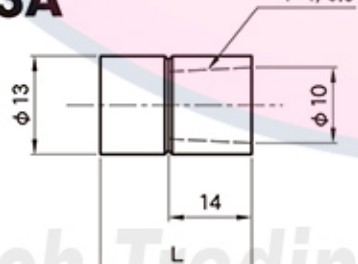
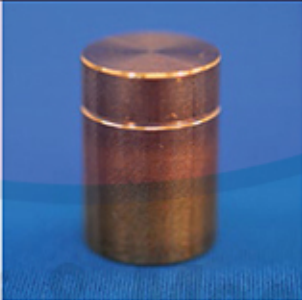
### T-CT-F-13A

Model No. 型式	L 全長
T-CT-F-13A	20
T-CT-F-1323A	23
T-CT-F-1325A	25

material(材質) : CrCu(クローム銅)

Mastech Trading &amp; Machining co.,Ltd.



# Cap Tip

$\phi 16 \times 23$  type Taper  $\phi 12.6 \times 1/9.6$

キャップチップ material(材質) : CrCu(クローム銅)

Unit(単位):mm

## T-CT-R-16×6A

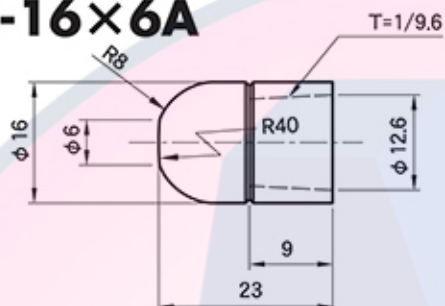

Model No. 型式	L 全長
T-CT-R-16×6A	23

material(材質) : CrCu(クローム銅)

Unit(単位):mm

## T-CT-16×8RA

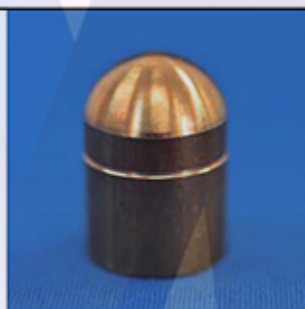
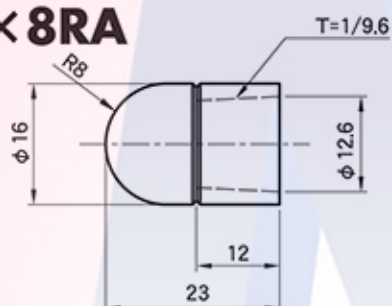

Model No. 型式	L 全長
T-CT-16×8RA	23

material(材質) : CrCu(クローム銅)

Unit(単位):mm

## T-CT-B×16A

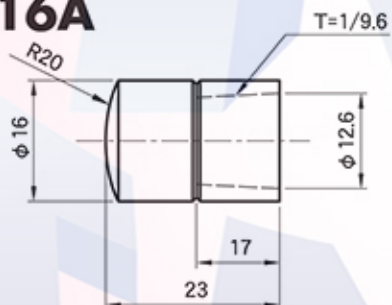

Model No. 型式	L 全長
T-CT-B×16A	23

material(材質) : CrCu(クローム銅)

Unit(単位):mm

## T-CT-P-16×6A

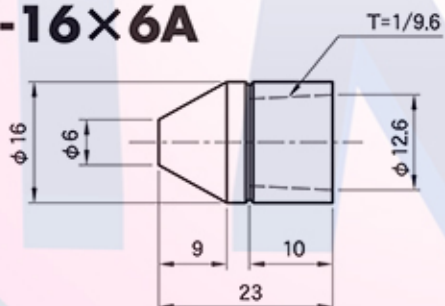

Model No. 型式	L 全長
T-CT-P-16×6A	23

material(材質) : CrCu(クローム銅)

Unit(単位):mm

## T-CT-D-16×6A

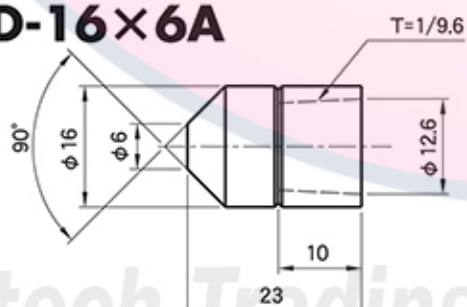

Model No. 型式	L 全長
T-CT-D-16×6A	23

material(材質) : CrCu(クローム銅)

# Cap Tip

$\phi 16 \times 23$  type Taper  $\phi 12.6 \times 1/9.6$

キャップチップ material(材質): CrCu(クローム銅)

Unit(単位):mm

## T-CT-C-16×6A

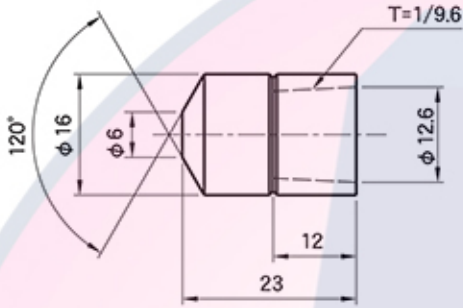

Model No. 型式	L 全長
T-CT-C-16×6A	23

material(材質): CrCu(クローム銅)

Unit(単位):mm

## T-CT-E-16×6A

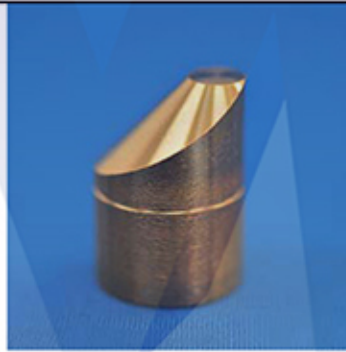
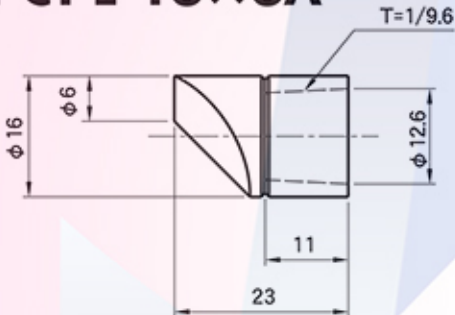

Model No. 型式	L 全長
T-CT-E-16×6A	23

material(材質): CrCu(クローム銅)

Unit(単位):mm

## T-CT-F-16A

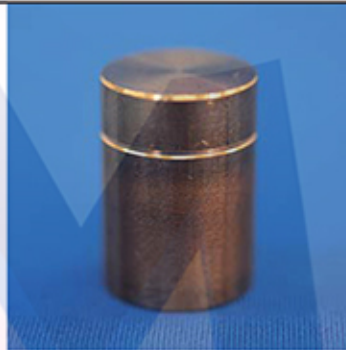
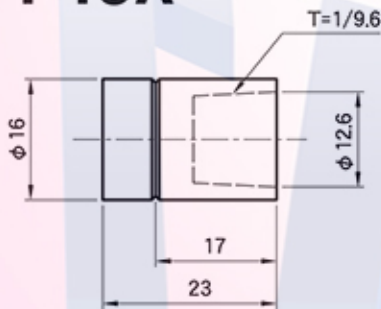

Model No. 型式	L 全長
T-CT-F-16A	23

material(材質): CrCu(クローム銅)

Mastech Trading & Machining co.,ltd.



# Cap Tip

$\phi 13 \times 20$  type Taper  $\phi 10 \times 1/10$

キャップチップ material(材質): CrCu(クローム銅)

Unit(単位):mm

## N-13-15R

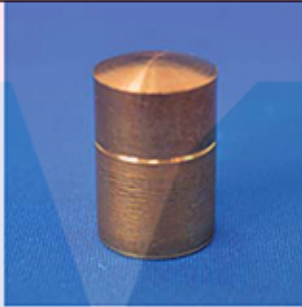

Model No. 型式	L 全長
N-13-15R	20
material(材質): CrCu(クローム銅)	

Unit(単位):mm

## N-13-D

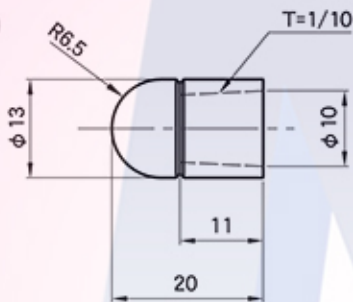

Model No. 型式	L 全長
N-13-D	20
material(材質): CrCu(クローム銅)	

Unit(単位):mm

## N-13-P

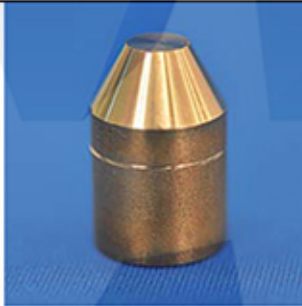
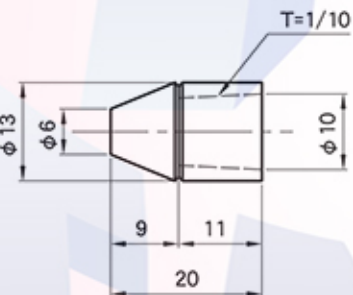

Model No. 型式	L 全長
N-13-P	20
material(材質): CrCu(クローム銅)	

Unit(単位):mm

## N-13-E

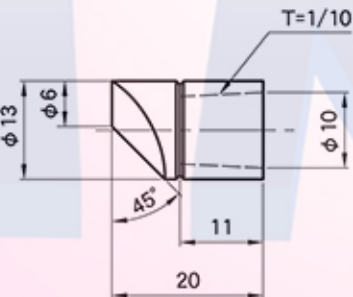

Model No. 型式	L 全長
N-13-E	20
material(材質): CrCu(クローム銅)	

Unit(単位):mm

## N-13-F

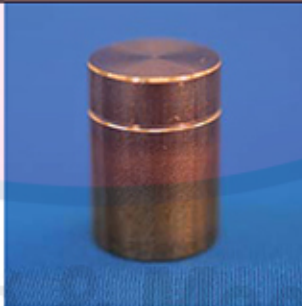
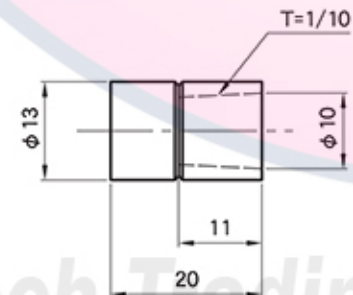

Model No. 型式	L 全長
N-13-F	20
material(材質): CrCu(クローム銅)	

Mastech Trading & Machining co., Ltd.

# Cap Tip

$\phi 16 \times 25$  type Taper  $\phi 12.7 \times 1/10$

キャップチップ material(材質) : CrCu(クローム銅)

		Unit(単位):mm	
<b>N-16-F</b>		Model No. 型式	L 全長
		N-16-F	25
		material(材質) : CrCu(クローム銅)	
<b>N-16-D</b>		Model No. 型式	L 全長
		N-16-D	25
		material(材質) : CrCu(クローム銅)	
<b>N-16-R</b>		Model No. 型式	L 全長
		N-16-R	25
		material(材質) : CrCu(クローム銅)	
<b>N-16-P</b>		Model No. 型式	L 全長
		N-16-P	25
		material(材質) : CrCu(クローム銅)	
<b>N-16-E</b>		Model No. 型式	L 全長
		N-16-E	25
		material(材質) : CrCu(クローム銅)	



# Cap Tip

$\phi 13 \times 20$  type Taper  $\phi 10 \times 1/9.6$

キャップチップ

material(材質) :  $Al_2O_3Cu$ (アルミナ分散強化銅)

Unit(単位):mm

## T-CT-R-13×6B

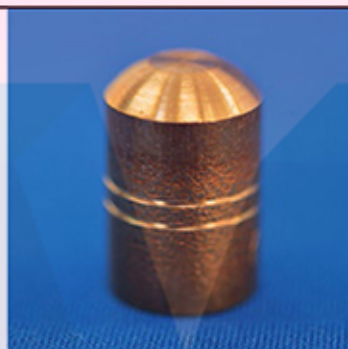
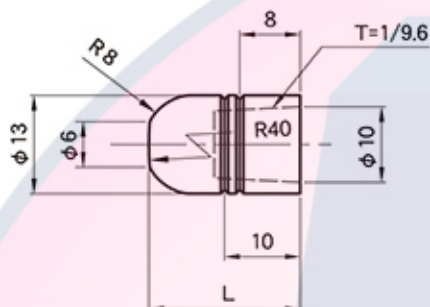

Model No. 型式	L 全長
T-CT-R-13×6B	20
T-CT-R-1323×6B	23
T-CT-R-1325×6B	25

material(材質) :  $Al_2O_3Cu$ (アルミナ分散強化銅)

Unit(単位):mm

## T-CT-13×6.5RB

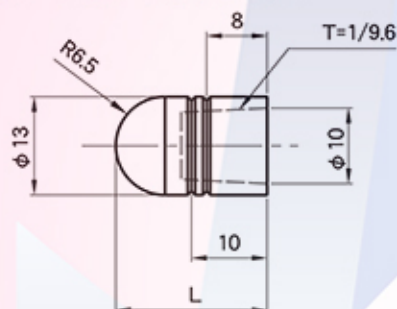

Model No. 型式	L 全長
T-CT-13×6.5RB	20
T-CT-1323×6.5RB	23
T-CT-1325×6.5RB	25

material(材質) :  $Al_2O_3Cu$ (アルミナ分散強化銅)

Unit(単位):mm

## T-CT-P-13×6B

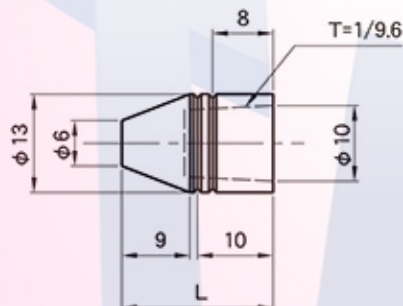

Model No. 型式	L 全長
T-CT-P-13×6B	20
T-CT-P-1323×6B	23
T-CT-P-1325×6B	25

material(材質) :  $Al_2O_3Cu$ (アルミナ分散強化銅)

Unit(単位):mm

## T-CT-F-13B

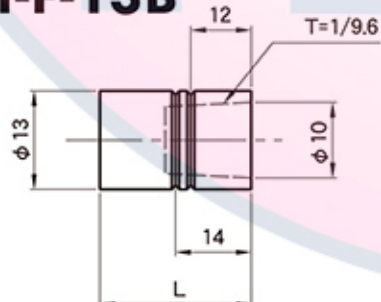

Model No. 型式	L 全長
T-CT-F-13B	20
T-CT-F-1323B	23
T-CT-F-1325B	25

material(材質) :  $Al_2O_3Cu$ (アルミナ分散強化銅)

Mastech Trading & Machining co.,ltd.

# Cap Tip

$\phi 13 \times 20$  type Taper  $\phi 10 \times 1/9.6$

キャップチップ

material(材質) :  $Al_2O_3Cu$ (アルミナ分散強化銅)

Unit(単位):mm

## T-CT-C-13×6B

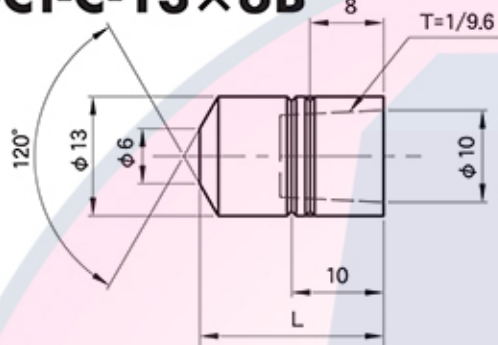

Model No. 型式	L 全長
T-CT-C-13×6B	20
T-CT-C-1323×6B	23
T-CT-C-1325×6B	25

material(材質) :  $Al_2O_3Cu$ (アルミナ分散強化銅)

Unit(単位):mm

## T-CT-D-13×6B

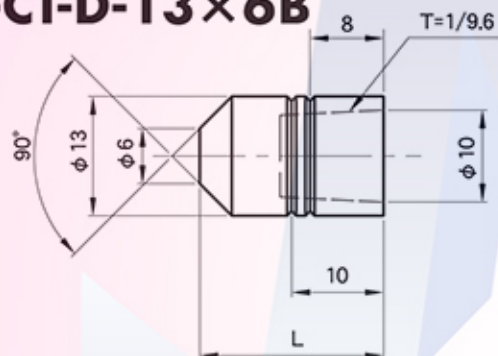

Model No. 型式	L 全長
T-CT-D-13×6B	20
T-CT-D-1323×6B	23
T-CT-D-1325×6B	25

material(材質) :  $Al_2O_3Cu$ (アルミナ分散強化銅)

Unit(単位):mm

## T-CT-E-13×6B

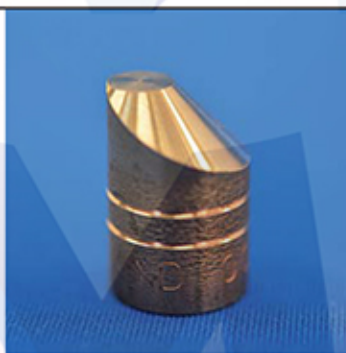
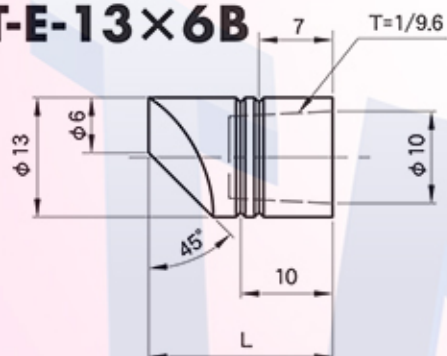

Model No. 型式	L 全長
T-CT-E-13×6B	20
T-CT-E-1323×6B	23
T-CT-E-1325×6B	25

material(材質) :  $Al_2O_3Cu$ (アルミナ分散強化銅)

Unit(単位):mm

## T-CT-B×13B

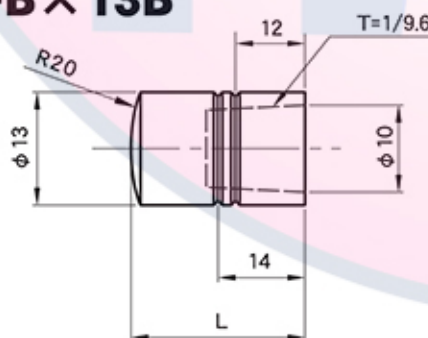

Model No. 型式	L 全長
T-CT-B×13B	20
T-CT-B×1323B	23
T-CT-B×1325B	25

material(材質) :  $Al_2O_3Cu$ (アルミナ分散強化銅)

Mastech Trading & Machining co.,ltd.



# Cap Tip

$\phi 16 \times 23$  type Taper  $\phi 12.6 \times 1/9.6$

キャップチップ

material(材質) : Al<sub>2</sub>O<sub>3</sub>Cu(アルミナ分散強化銅)

Unit(単位):mm

## T-CT-R-16×6B

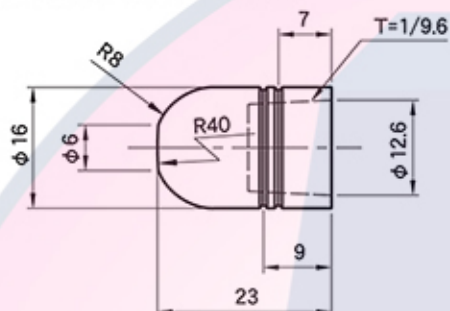

Model No. 型式	L 全長
T-CT-R-16×6B	23

material(材質) : Al<sub>2</sub>O<sub>3</sub>Cu(アルミナ分散強化銅)

Unit(単位):mm

## T-CT-16×8RB

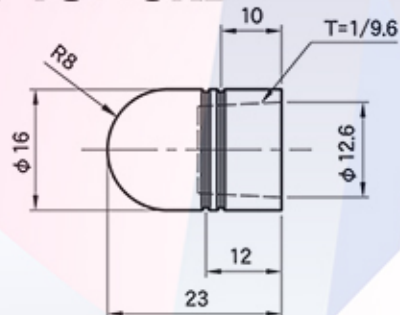

Model No. 型式	L 全長
T-CT-16×8RB	23

material(材質) : Al<sub>2</sub>O<sub>3</sub>Cu(アルミナ分散強化銅)

Unit(単位):mm

## T-CT-B-16B

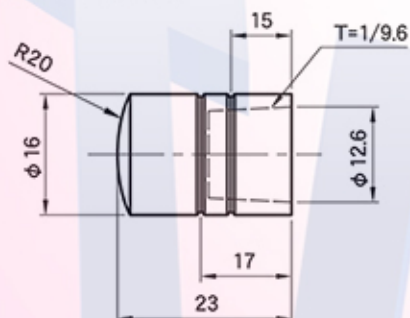

Model No. 型式	L 全長
T-CT-B-16B	23

material(材質) : Al<sub>2</sub>O<sub>3</sub>Cu(アルミナ分散強化銅)

Unit(単位):mm

## T-CT-P-16×6B

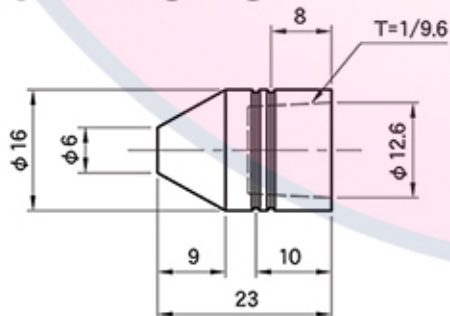

Model No. 型式	L 全長
T-CT-P-16×6B	23

material(材質) : Al<sub>2</sub>O<sub>3</sub>Cu(アルミナ分散強化銅)

Mastech Trading & Machining co.,Ltd.

# Cap Tip

$\phi 16 \times 23$  type Taper  $\phi 12.6 \times 1/9.6$

キャップチップ

material(材質) :  $Al_2O_3Cu$ (アルミナ分散強化銅)

Unit(単位):mm

## T-CT-D-16×6B

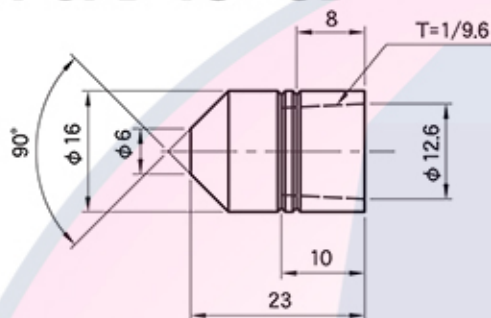

Model No. 型式	L 全長
T-CT-D-16×6B	23

material(材質) :  $Al_2O_3Cu$ (アルミナ分散強化銅)

Unit(単位):mm

## T-CT-C-16×6B

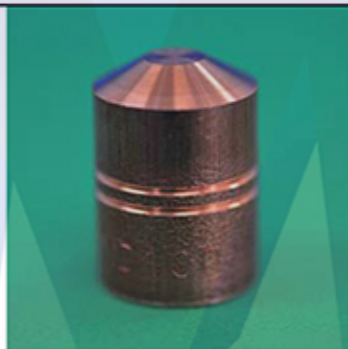
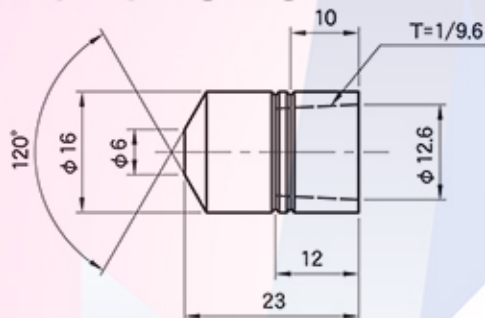

Model No. 型式	L 全長
T-CT-C-16×6B	23

material(材質) :  $Al_2O_3Cu$ (アルミナ分散強化銅)

Unit(単位):mm

## T-CT-E-16×6B

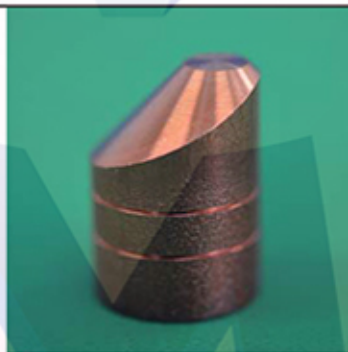
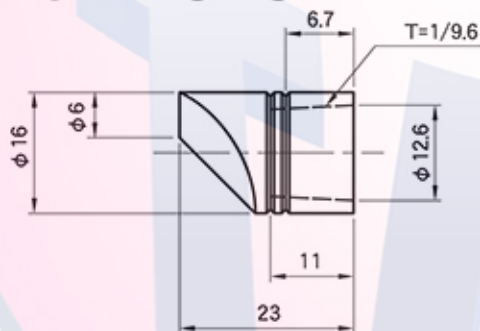

Model No. 型式	L 全長
T-CT-E-16×6B	23

material(材質) :  $Al_2O_3Cu$ (アルミナ分散強化銅)

Unit(単位):mm

## T-CT-F-16B

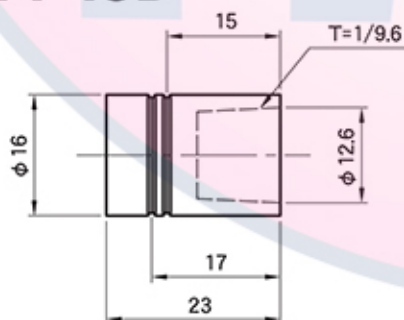

Model No. 型式	L 全長
T-CT-F-16B	23

material(材質) :  $Al_2O_3Cu$ (アルミナ分散強化銅)



# Cap Tip

$\phi 13 \times 20$  type Taper  $\phi 10 \times 1/10$

キャップチップ

material(材質) :  $Al_2O_3Cu$ (アルミナ分散強化銅)

Unit(単位):mm

## N-13-R-B

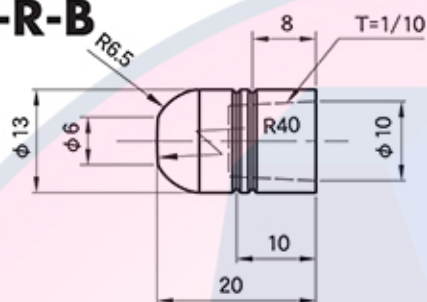

Model No. 型式	L 全長
N-13-R-B	20

material(材質) :  $Al_2O_3Cu$ (アルミナ分散強化銅)

Unit(単位):mm

## N-13-D-B

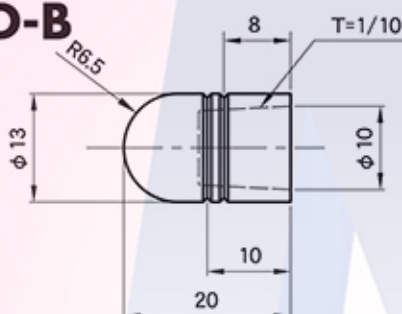

Model No. 型式	L 全長
N-13-D-B	20

material(材質) :  $Al_2O_3Cu$ (アルミナ分散強化銅)

Unit(単位):mm

## N-13-P-B

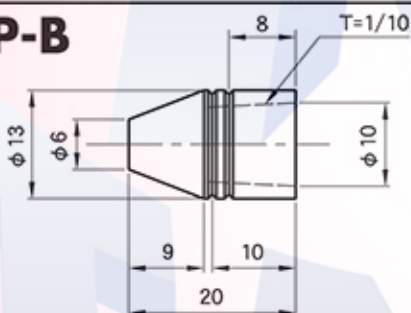

Model No. 型式	L 全長
N-13-P-B	20

material(材質) :  $Al_2O_3Cu$ (アルミナ分散強化銅)

Unit(単位):mm

## N-13-E-B

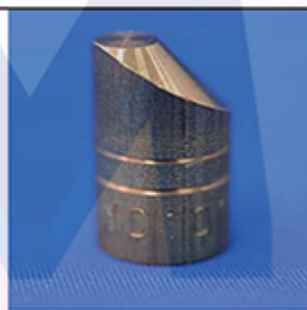
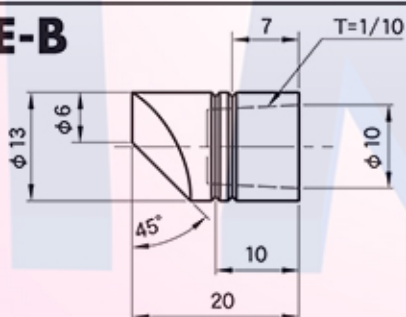

Model No. 型式	L 全長
N-13-E-B	20

material(材質) :  $Al_2O_3Cu$ (アルミナ分散強化銅)

Unit(単位):mm

## N-13-F-B

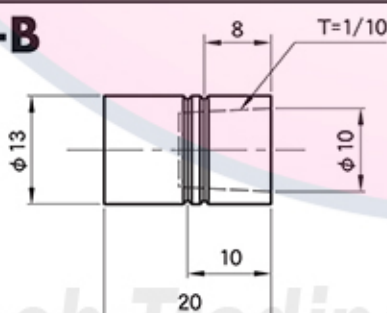

Model No. 型式	L 全長
N-13-F-B	20

material(材質) :  $Al_2O_3Cu$ (アルミナ分散強化銅)

# Cap Tip

$\phi 16 \times 25$  type Taper  $\phi 12.7 \times 1/10$

キャップチップ material(材質) :  $Al_2O_3Cu$ (アルミナ分散強化銅)

Unit(単位):mm					
<b>N-16-F-B</b> 	<table border="1"> <tr> <th>Model No. 型式</th> <th>L 全長</th> </tr> <tr> <td>N-16-F-B</td> <td>25</td> </tr> </table>	Model No. 型式	L 全長	N-16-F-B	25
	Model No. 型式	L 全長			
N-16-F-B	25				
	material(材質) : $Al_2O_3Cu$ (アルミナ分散強化銅)				
<b>N-16-D-B</b> 	<table border="1"> <tr> <th>Model No. 型式</th> <th>L 全長</th> </tr> <tr> <td>N-16-D-B</td> <td>25</td> </tr> </table>	Model No. 型式	L 全長	N-16-D-B	25
	Model No. 型式	L 全長			
N-16-D-B	25				
	material(材質) : $Al_2O_3Cu$ (アルミナ分散強化銅)				
<b>N-16-R-B</b> 	<table border="1"> <tr> <th>Model No. 型式</th> <th>L 全長</th> </tr> <tr> <td>N-16-R-B</td> <td>25</td> </tr> </table>	Model No. 型式	L 全長	N-16-R-B	25
	Model No. 型式	L 全長			
N-16-R-B	25				
	material(材質) : $Al_2O_3Cu$ (アルミナ分散強化銅)				
<b>N-16-P-B</b> 	<table border="1"> <tr> <th>Model No. 型式</th> <th>L 全長</th> </tr> <tr> <td>N-16-P-B</td> <td>25</td> </tr> </table>	Model No. 型式	L 全長	N-16-P-B	25
	Model No. 型式	L 全長			
N-16-P-B	25				
	material(材質) : $Al_2O_3Cu$ (アルミナ分散強化銅)				
<b>N-16-E-B</b> 	<table border="1"> <tr> <th>Model No. 型式</th> <th>L 全長</th> </tr> <tr> <td>N-16-E-B</td> <td>25</td> </tr> </table>	Model No. 型式	L 全長	N-16-E-B	25
	Model No. 型式	L 全長			
N-16-E-B	25				
	material(材質) : $Al_2O_3Cu$ (アルミナ分散強化銅)				





Cap Tip  
キャップチップ

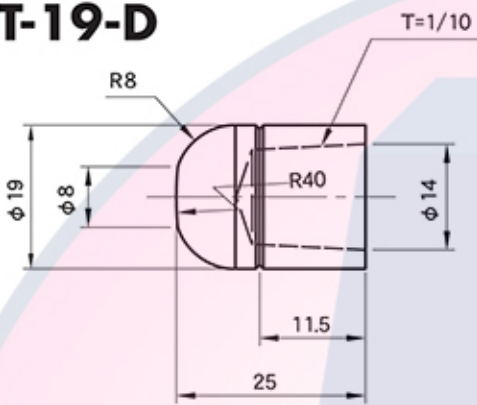

# Cap Tip

$\phi 19 \times 25$  type Taper  $\phi 14 \times 1/10$

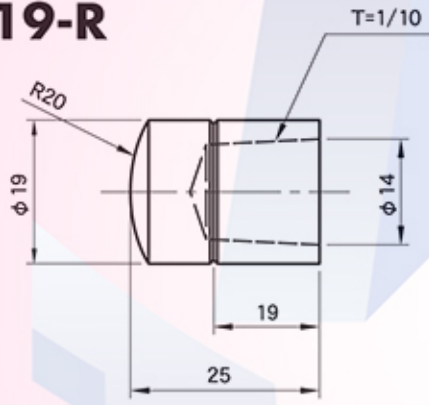
キャップチップ material(材質) : CrCu(クローム銅)

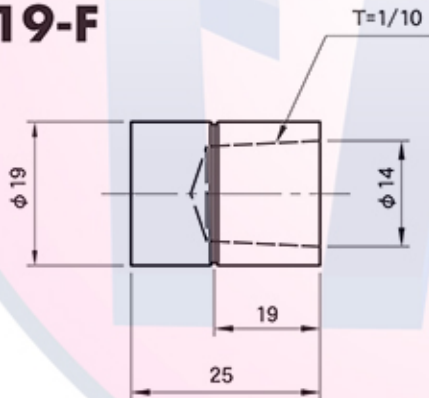
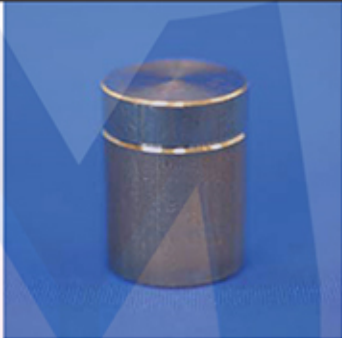
		Unit(単位):mm	
<b>T-19-D</b> 		Model No. 型式	L 全長
		T-19-D	25
		material(材質) : CrCu(クローム銅)	
<b>T-19-R</b> 		Model No. 型式	L 全長
		T-19-R	25
		material(材質) : CrCu(クローム銅)	
<b>T-19-F</b> 		Model No. 型式	L 全長
		T-19-F	25
		material(材質) : CrCu(クローム銅)	

Mastech Trading & Machining co.,ltd.

Electrode for Spot Welder

# Cap Tip

$\phi 22 \times 25$  type Taper  $\phi 16 \times 1/10$

キャップチップ material(材質): CrCu(クローム銅)



**N-22-R**

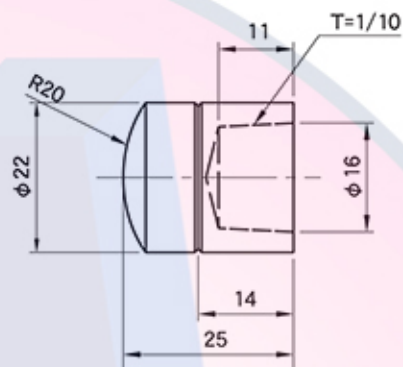

**N-22-P**

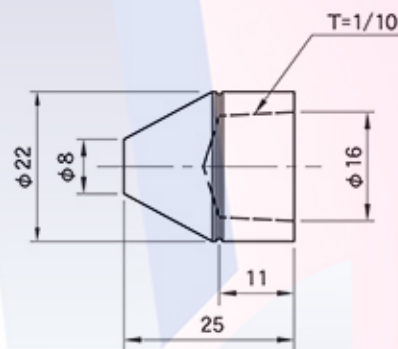

**N-22-F**

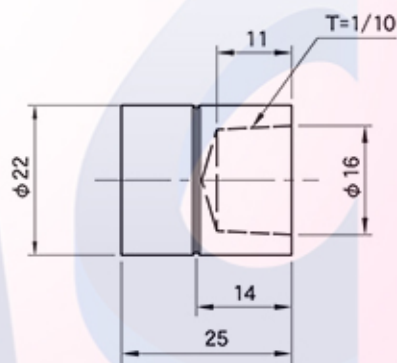

**N-22-E**

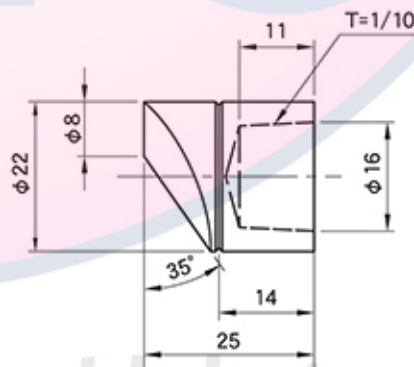

Mastech Trading & Machining co.,ltd.