

Lower Electrode Assy with KCF Guide Pin

KCFガイドピン付下部電極Assy



W-PN-AK type

Spring type
スプリングタイプ

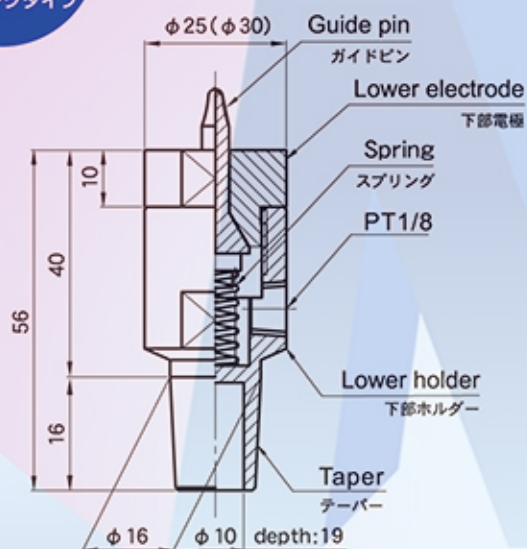

Air type
エアタイプ

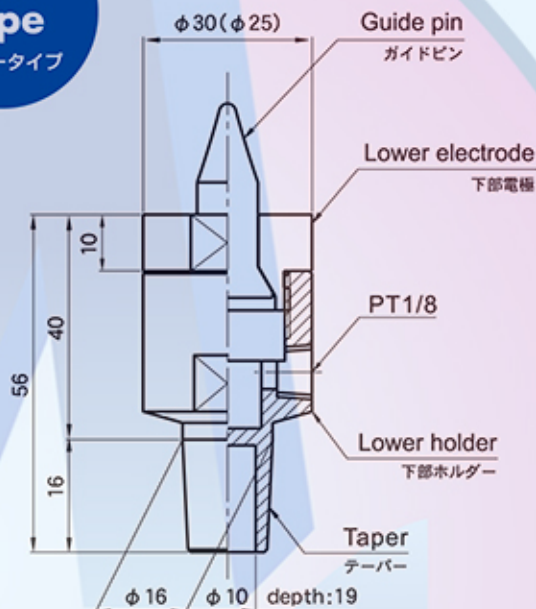

Spring
スプリング

Model:SWY11-25

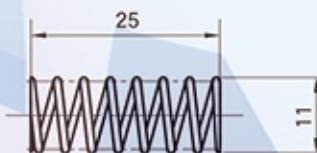

Spring Cap

スプリング受

Model:SPGCJ10-7-3

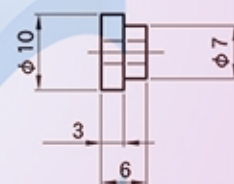

W-PN-AK-□-□-□-□

Nut size Guide pin Dia taper No. Air type...A
ナットサイズ ガイドピン外径 テーパーNo. Spring type...S

Please order with the model number on the left.

ご注文は左記の記号にてお願いいたします。

Lower Electrode Assy 下部電極(Assy)

Unit(単位):mm

Nut size ナットサイズ	Model No. 型 式	Guidepin Dia ガイドピン径φ	Electrode Outer Dia 電極外径φ	Total Length 全 長	Taper1 テーパー1	Taper2 テーパー2	Taper3 テーパー3
M 4	W-PN-AK-4	4.8	25	56	16×1/10	15.875×MT [#] 2	16×1/5
M 5	W-PN-AK-5	5.8	25	56	16×1/10	15.875×MT [#] 2	16×1/5
M 6	W-PN-AK-6	6.8	25	56	16×1/10	15.875×MT [#] 2	16×1/5
M 8	W-PN-AK-8	8.8	25	56	16×1/10	15.875×MT [#] 2	16×1/5
M10	W-PN-AK-10	10.8	30	56	16×1/10	15.875×MT [#] 2	16×1/5
M12	W-PN-AK-12	12.8	30	56	16×1/10	15.875×MT [#] 2	16×1/5

Lower Electrode Assy with KCF Guide Pin

KCFガイドピン付下部電極Assy



Long Stroke K type

Spring type
スプリングタイプ

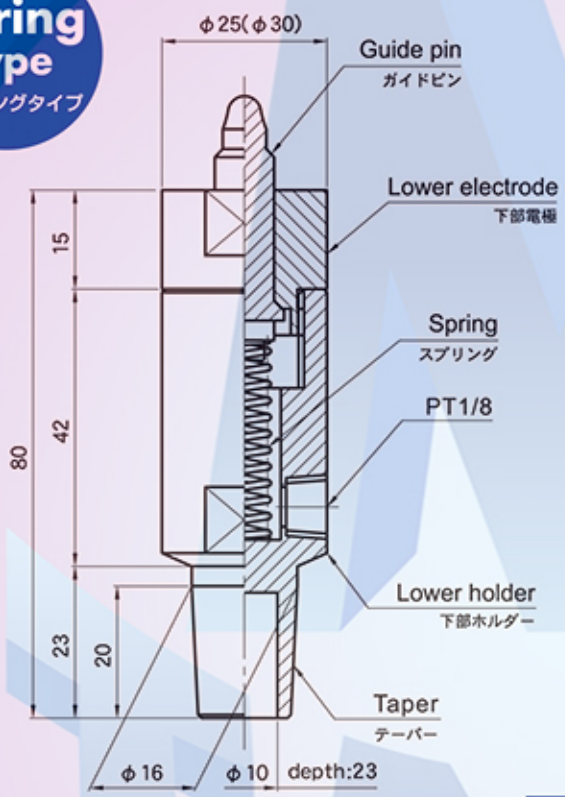

Air type
エアタイプ

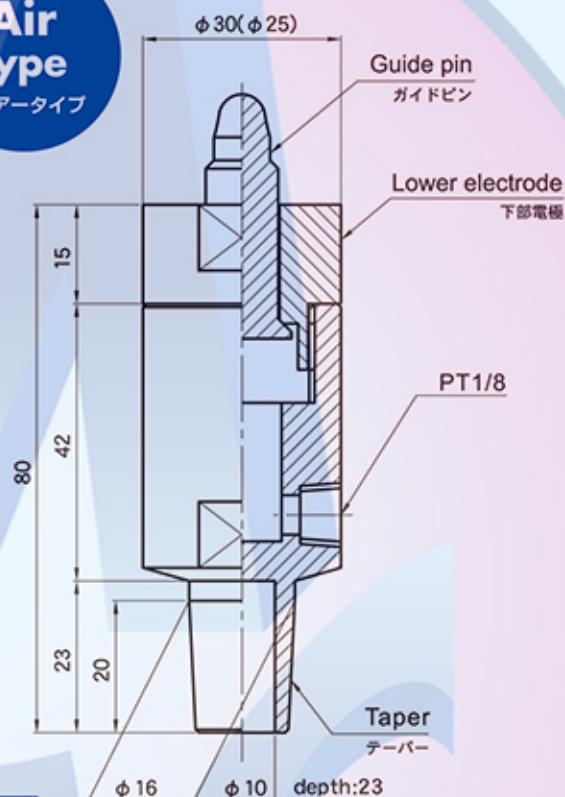

Spring
スプリング
Model:SWY11-35

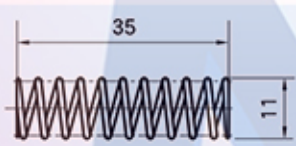

Spring Cap
スプリング受
Model:SPGCJ10-7-3

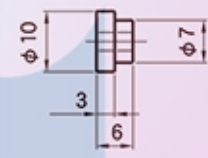

LS-AK-□-□-□-□

Nut size Guide pin Dia taper No. Air type...A
ナットサイズ ガイドピン外径 テーパーNo. Spring type...S

Please order with the model number on the left.
ご注文は左記の記号にてお願いいたします。

Lower Electrode Assy 下部電極(Assy)

Unit(単位):mm

Nut size ナットサイズ	Model No. 型式	Guidepin Dia ガイドピン径φ	Electrode Outer Dia 電極外径φ	Total Length 全長	Taper1 テーパー1	Taper2 テーパー2	Taper3 テーパー3
M4	LS-AK-4	4.8	25	80	16×1/10	15.875×MT#2	16×1/5
M5	LS-AK-5	5.8	25	80	16×1/10	15.875×MT#2	16×1/5
M6	LS-AK-6	6.8	25	80	16×1/10	15.875×MT#2	16×1/5
M8	LS-AK-8	8.8	25	80	16×1/10	15.875×MT#2	16×1/5
M10	LS-AK-10	10.8	30	80	16×1/10	15.875×MT#2	16×1/5
M12	LS-AK-12	12.8	30	80	16×1/10	15.875×MT#2	16×1/5

Lower Electrode & Holder

ナット溶接用下部電極・下部ホルダー



Lower Electrode for Welding Nut

ナット溶接用下部電極

W-PN-C/CA

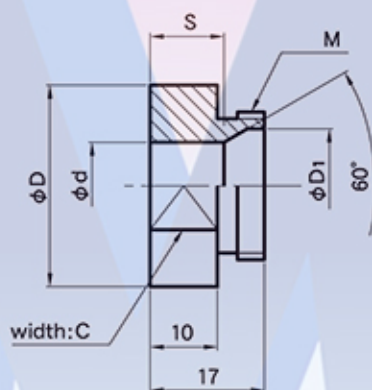

Please order with the model number below.
ご注文は下記の記号にてお願いいたします。

W-PN-C

↑
Nut size
ナットサイズ

Unit(単位):mm

Model No. 型式	φd	φD	φD1	M	C	S
W-PN-C 4	5	25	13	18×P1.5	22	12
W-PN-C 5	6	25	13	18×P1.5	22	12
W-PN-C 6	7	25	13	18×P1.5	22	12
W-PN-C 8	9	25	13	18×P1.5	22	12
W-PN-C 10	11	30	17	22×P1.5	27	12
W-PN-C 12	13	30	17	22×P1.5	27	12

material(材質): CrCu(クローム銅)

Please order with the model number below.
ご注文は下記の記号にてお願いいたします。

W-PN-C **A**

↑
Nut size
ナットサイズ

Unit(単位):mm

Model No. 型式	φd	φD	φD1	M	C	S
W-PN-C 4A	5	25	13	18×P1.5	22	9
W-PN-C 5A	6	25	13	18×P1.5	22	9
W-PN-C 6A	7	25	13	18×P1.5	22	9
W-PN-C 8A	9	25	13	18×P1.5	22	9
W-PN-C 10A	11	30	17	22×P1.5	27	9
W-PN-C 12A	13	30	17	22×P1.5	27	9

material(材質): CrCu(クローム銅)

Mastech Trading & Machining co.,Ltd.

Lower Electrode & Holder

ナット溶接用下部電極・下部ホルダー

Lower Holder

下部ホルダー

W-PN-B3

φ 25

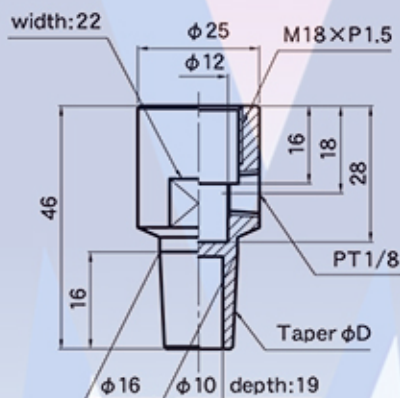

W-PN-B2

φ 30

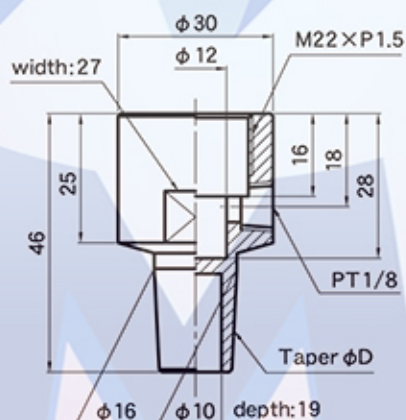

Unit(単位):mm

Please order with the model number below.

ご注文は下記の記号にてお願いいたします。

W-PN-B

Model No.

型式

Model No. 型式	Outside Dia 外径 φD	Thread M ネジM	Taper テーパ φD
W-PN-B3-1	25	18	16×1/10
W-PN-B3-2	25	18	16×1/5
W-PN-B3-M2	25	18	15.875×MT#2
W-PN-B2-1	30	22	16×1/10
W-PN-B2-2	30	22	16×1/5
W-PN-B2-M2	30	22	15.875×MT#2

material(材質): CrCu(クローム銅)

Mastech Trading & Machining Co., Ltd.

Lower Electrode & Holder for Long stroke type

ナット溶接用下部電極・下部ホルダー



Long Stroke type

芯ズレ防止タイプ

Lower Electrode for Welding Nut

ナット溶接用下部電極

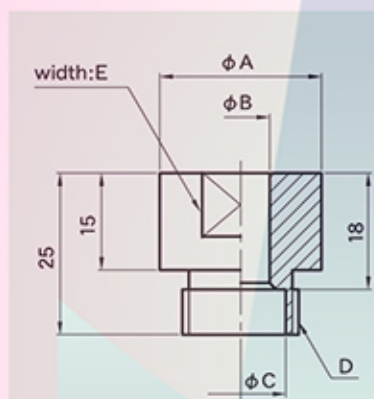

Lower Electrode

Unit(単位):mm

Model No. 型式	φA	φB	φC	D	E
125MO-□	25	-	12.5	M18	22
130MO-□	30	-	16.5	M22	27
135MO-□	35	-	16.5	M22	32

material(材質): CrCu(クローム銅)

Please put the outside diameter of Guide Pin in the box '□'.
□内にガイドピン外径寸法を記入下さい。

Lower Holder

下部ホルダー

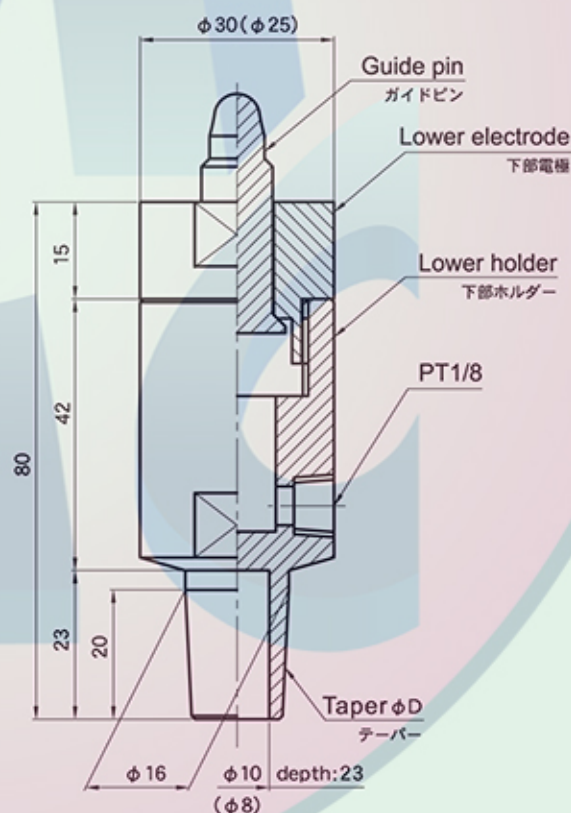
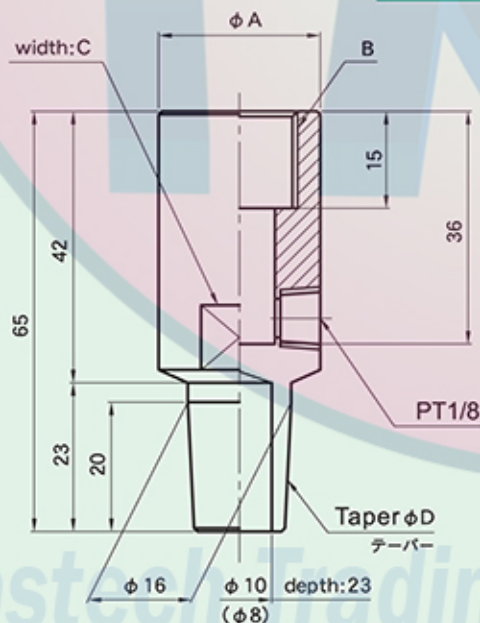

Lower Holder

Unit(単位):mm

Model No. 型式	φA	B	C	Taper テーパφD
125MF	25	M18	22	121/10.161/10.161/5.16MT ₂
130MF	30	M22	27	161/10.161/5.16MT ₂
135MF	35	M22	32	161/10.161/5.16MT ₂

material(材質): CrCu(クローム銅)