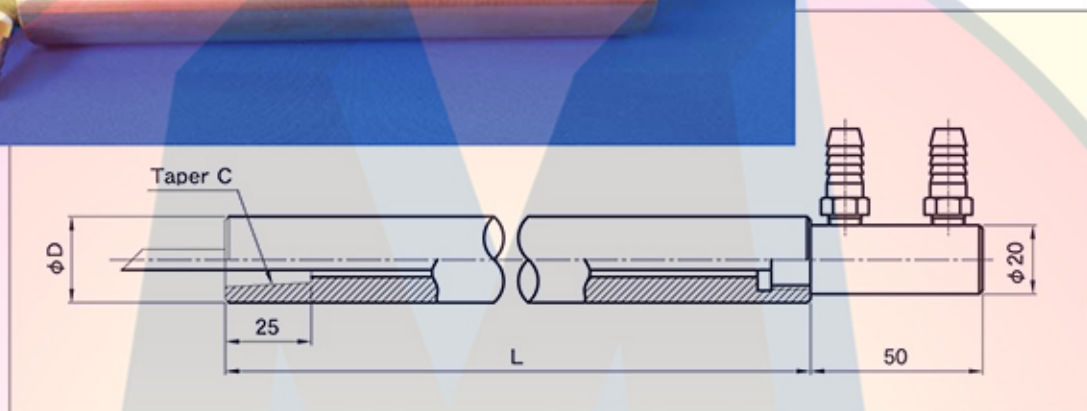

Straight Holder

ストレートホルダー

 $\phi 20$ $\phi 22$ $\phi 25$ type

Unit(単位):mm

| Model No. 型式 | Dia 軸径 ϕD | L ホルダー長 | Outside Dia チップ外径 ϕd | TipTaper チップテーパC |
|-----------------|--------------------|------------|-------------------------------|---------------------|
| SH-20150-12-1 | 20 | 150 | 12 | 1/10 |
| SH-20200-12-1 | 20 | 200 | 12 | 1/10 |
| SH-22150-12-1 | 22 | 150 | 12 | 1/10 |
| SH-22200-12-1 | 22 | 200 | 12 | 1/10 |
| SH-22250-12-1 | 22 | 250 | 12 | 1/10 |
| SH-25150-12-1 | 25 | 150 | 12 | 1/10 |
| SH-25150-16-1 | 25 | 150 | 16 | 1/10 |
| SH-25150-16-3 | 25 | 150 | 16 | 1/5 |
| SH-25200-12-1 | 25 | 200 | 12 | 1/10 |
| SH-25200-16-1 | 25 | 200 | 16 | 1/10 |
| SH-25200-16-3 | 25 | 200 | 16 | 1/5 |
| SH-25200-16-2 | 25 | 200 | 15.875 | MT#2 |
| SH-25250-12-1 | 25 | 250 | 12 | 1/10 |
| SH-25250-16-1 | 25 | 250 | 16 | 1/10 |
| SH-25250-16-3 | 25 | 250 | 16 | 1/5 |
| SH-25250-16-2 | 25 | 250 | 15.875 | MT#2 |
| SH-25300-12-1 | 25 | 300 | 12 | 1/10 |
| SH-25300-16-1 | 25 | 300 | 16 | 1/10 |
| SH-25300-16-3 | 25 | 300 | 16 | 1/5 |
| SH-25300-16-2 | 25 | 300 | 15.875 | MT#2 |
| SH-25350-12-1 | 25 | 350 | 12 | 1/10 |
| SH-25350-16-1 | 25 | 350 | 16 | 1/10 |
| SH-25350-16-3 | 25 | 350 | 16 | 1/5 |
| SH-25350-16-2 | 25 | 350 | 15.875 | MT#2 |
| SH-25400-16-1 | 25 | 400 | 16 | 1/10 |
| SH-25500-16-1 | 25 | 500 | 16 | 1/10 |
| SH-25600-16-1 | 25 | 600 | 16 | 1/10 |

material(材質): CuB



Mastech Trading Co., Ltd.

Electrode for Spot Welder

Straight Holder $\phi 30$ $\phi 32$ type

ストレートホルダー

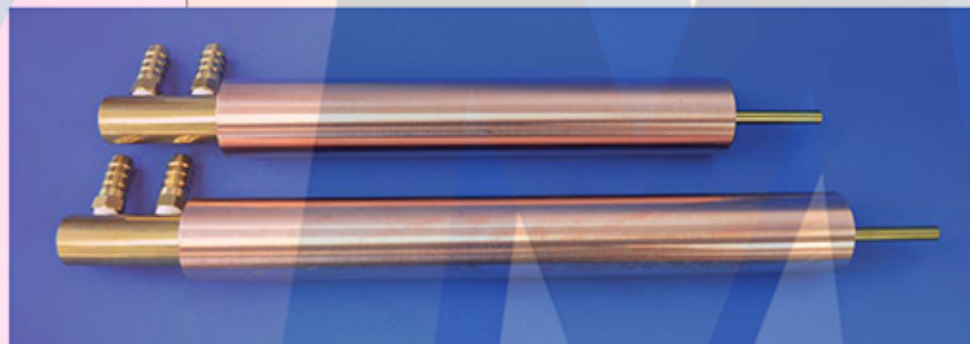
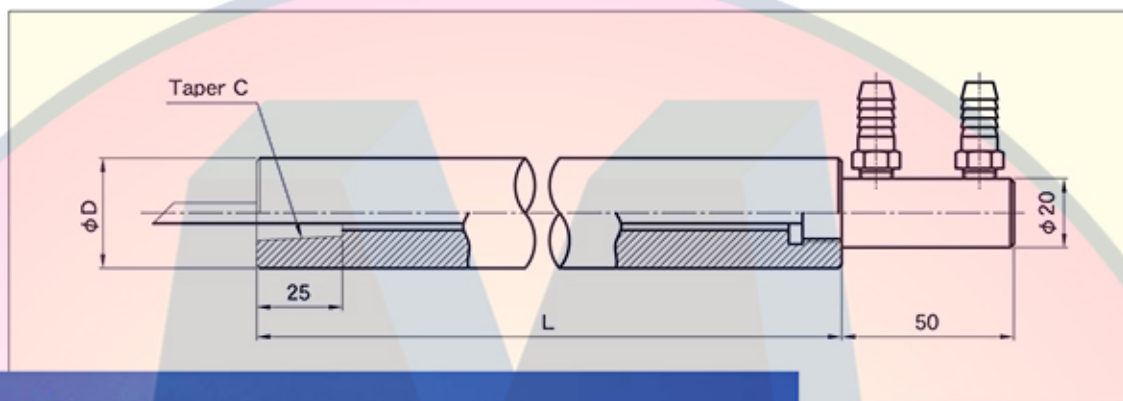

Unit(単位):mm

| Model No. 型式 | Dia 軸径 ϕD | L ホルダー長 | Outside Dia チップ外径 ϕd | Tip Taper チップテーパ-C |
|-----------------|--------------------|------------|-------------------------------|-----------------------|
| SH-30200-16-1 | 30 | 200 | 16 | 1/10 |
| SH-30250-16-1 | 30 | 250 | 16 | 1/10 |
| SH-30300-16-1 | 30 | 300 | 16 | 1/10 |
| SH-32200-16-1 | 32 | 200 | 16 | 1/10 |
| SH-32200-16-3 | 32 | 200 | 16 | 1/5 |
| SH-32200-20-1 | 32 | 200 | 20 | 1/10 |
| SH-32200-20-3 | 32 | 200 | 20 | 1/5 |
| SH-32250-16-1 | 32 | 250 | 16 | 1/10 |
| SH-32250-16-3 | 32 | 250 | 16 | 1/5 |
| SH-32250-16-2 | 32 | 250 | 15.875 | MT#2 |
| SH-32250-20-1 | 32 | 250 | 20 | 1/10 |
| SH-32250-20-3 | 32 | 250 | 20 | 1/5 |
| SH-32280-16-1 | 32 | 280 | 16 | 1/10 |
| SH-32300-16-1 | 32 | 300 | 16 | 1/10 |
| SH-32300-16-3 | 32 | 300 | 16 | 1/5 |
| SH-32300-16-2 | 32 | 300 | 15.875 | MT#2 |
| SH-32300-20-1 | 32 | 300 | 20 | 1/10 |
| SH-32300-20-3 | 32 | 300 | 20 | 1/5 |
| SH-32350-16-1 | 32 | 350 | 16 | 1/10 |
| SH-32400-16-1 | 32 | 400 | 16 | 1/10 |

material(材質): CuB

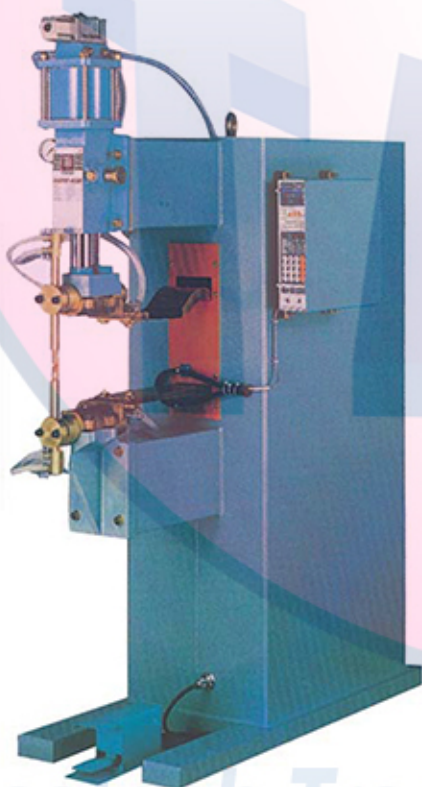

Mastech Trading Technology Co., Ltd.

Straight Holder

ストレートホルダー

Electrode for Spot Welder

Offset Holder

φ25 90° type

L型ホルダー φ25×90°

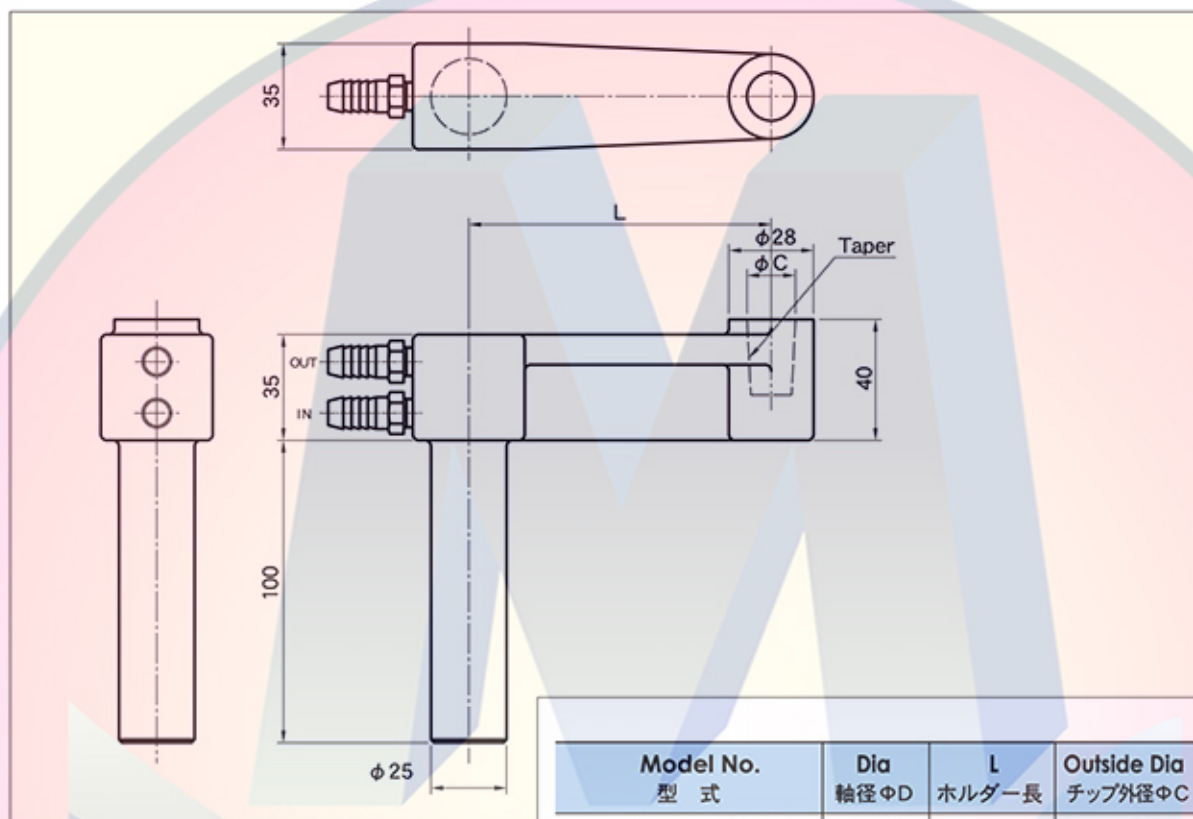

Unit(単位):mm

| Model No. 型式 | Dia 軸径φD | L ホルダー長 | Outside Dia チップ外径φC | TipTaper チップテーパー |
|-----------------|-------------|------------|------------------------|---------------------|
| LH-2550-12-1 | 25 | 50 | 12 | 1/10 |
| LH-2550-16-1 | 25 | 50 | 16 | 1/10 |
| LH-2550-16-3 | 25 | 50 | 16 | 1/5 |
| LH-2550-16-2 | 25 | 50 | 15.875 | MT#2 |
| LH-2570-12-1 | 25 | 70 | 12 | 1/10 |
| LH-2570-16-1 | 25 | 70 | 16 | 1/10 |
| LH-2570-16-3 | 25 | 70 | 16 | 1/5 |
| LH-2570-16-2 | 25 | 70 | 15.875 | MT#2 |
| LH-25100-12-1 | 25 | 100 | 12 | 1/10 |
| LH-25100-16-1 | 25 | 100 | 16 | 1/10 |
| LH-25100-16-3 | 25 | 100 | 16 | 1/5 |
| LH-25100-16-2 | 25 | 100 | 15.875 | MT#2 |
| LH-25120-12-1 | 25 | 120 | 12 | 1/10 |
| LH-25120-16-1 | 25 | 120 | 16 | 1/10 |
| LH-25120-16-3 | 25 | 120 | 16 | 1/5 |
| LH-25120-16-2 | 25 | 120 | 15.875 | MT#2 |
| LH-25150-12-1 | 25 | 150 | 12 | 1/10 |
| LH-25150-16-1 | 25 | 150 | 16 | 1/10 |
| LH-25150-16-3 | 25 | 150 | 16 | 1/5 |
| LH-25150-16-2 | 25 | 150 | 15.875 | MT#2 |

material(材質) : HB₃C₃

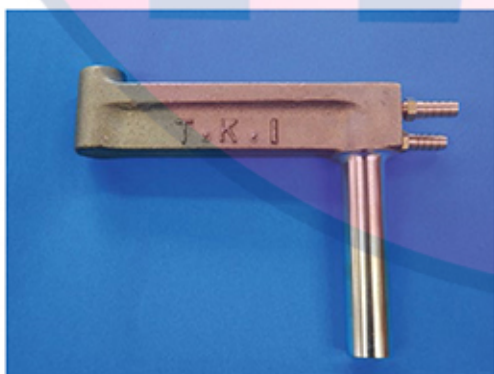
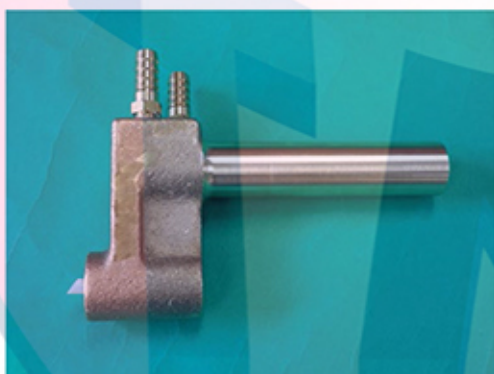

Mastech Trading & Machining Ltd.

Electrode for Spot Welder

Offset Holder

φ25 15° type

L型ホルダー φ25×15°

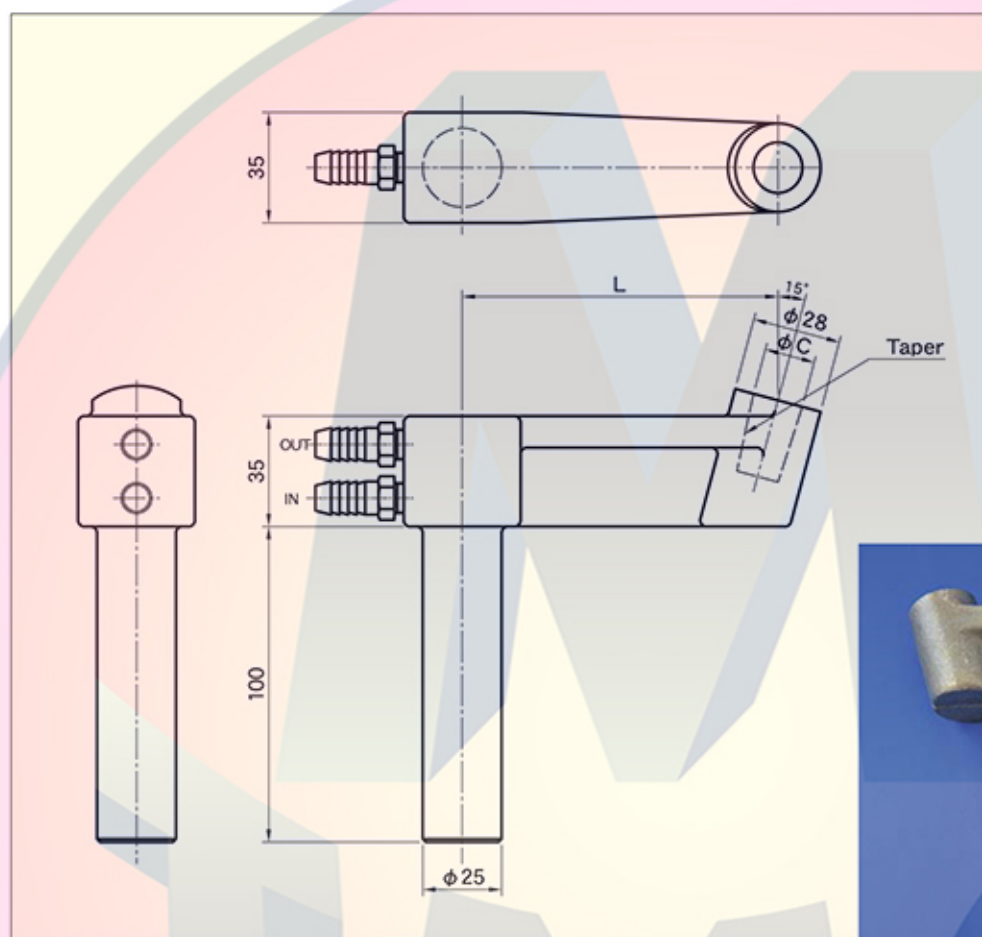

Unit(単位):mm

| Model No. 型式 | Dia 軸径φD | L ホルダー長 | Outside Dia チップ外径φC | Tip Taper チップテーパ |
|-----------------|-------------|------------|------------------------|---------------------|
| LH15-2550-12-1 | 25 | 50 | 12 | 1/10 |
| LH15-2550-16-1 | 25 | 50 | 16 | 1/10 |
| LH15-2550-16-3 | 25 | 50 | 16 | 1/5 |
| LH15-2550-16-2 | 25 | 50 | 15.875 | MT#2 |
| LH15-2570-12-1 | 25 | 70 | 12 | 1/10 |
| LH15-2570-16-1 | 25 | 70 | 16 | 1/10 |
| LH15-2570-16-3 | 25 | 70 | 16 | 1/5 |
| LH15-2570-16-2 | 25 | 70 | 15.875 | MT#2 |
| LH15-25100-12-1 | 25 | 100 | 12 | 1/10 |
| LH15-25100-16-1 | 25 | 100 | 16 | 1/10 |
| LH15-25100-16-3 | 25 | 100 | 16 | 1/5 |
| LH15-25100-16-2 | 25 | 100 | 15.875 | MT#2 |

material(材質): HB₃C₃

Offset Holder

L型ホルダー

Mastech Trading Co., Ltd. Machining co., Ltd.

Electrode for Spot Welder

Offset Holder

φ 32 90° type

L型ホルダー φ32×90°

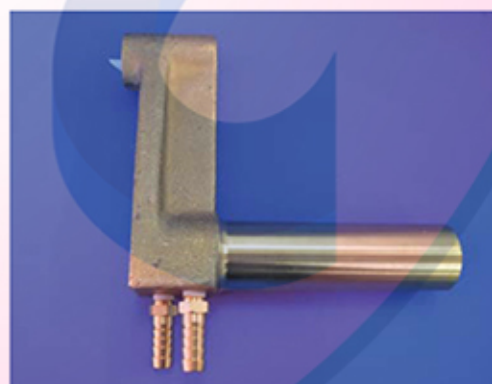
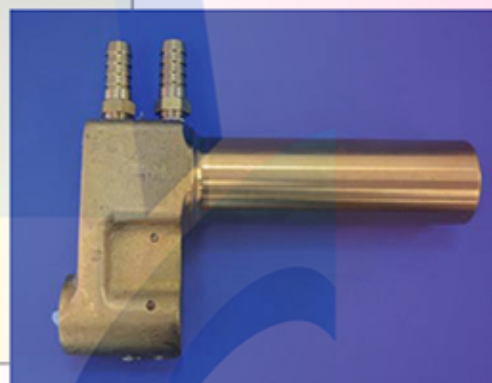
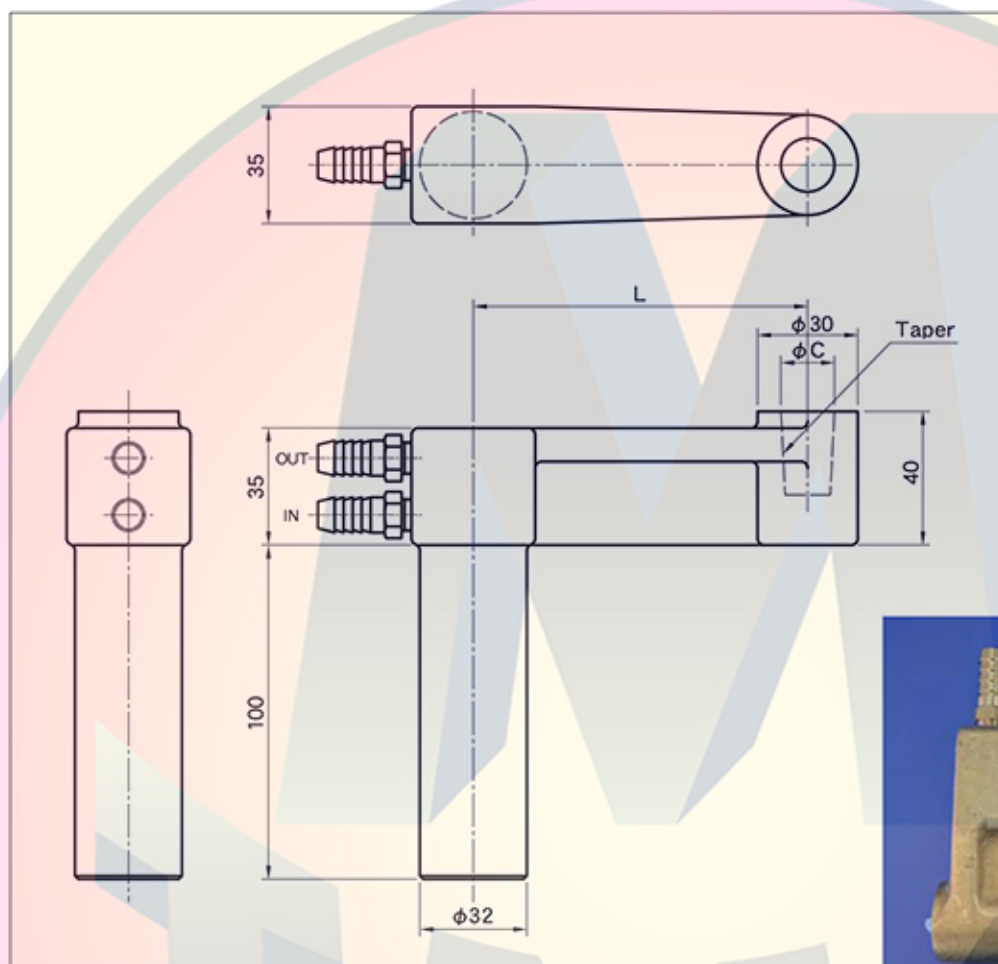

Unit(単位):mm

| Model No. 型式 | Dia 軸径φD | L ホルダー長 | Outside Dia チップ外径φC | TipTaper チップテーパ |
|-----------------|-------------|------------|------------------------|--------------------|
| LH-3250-16-1 | 32 | 50 | 16 | 1/10 |
| LH-3250-16-3 | 32 | 50 | 16 | 1/5 |
| LH-3250-16-2 | 32 | 50 | 15.875 | MT#2 |
| LH-3270-16-1 | 32 | 70 | 16 | 1/10 |
| LH-3270-16-3 | 32 | 70 | 16 | 1/5 |
| LH-3270-16-2 | 32 | 70 | 15.875 | MT#2 |
| LH-32100-16-1 | 32 | 100 | 16 | 1/10 |
| LH-32100-16-3 | 32 | 100 | 16 | 1/5 |
| LH-32100-16-2 | 32 | 100 | 15.875 | MT#2 |
| LH-32120-16-1 | 32 | 120 | 16 | 1/10 |
| LH-32120-16-3 | 32 | 120 | 16 | 1/5 |
| LH-32120-16-2 | 32 | 120 | 15.875 | MT#2 |
| LH-32150-16-1 | 32 | 150 | 16 | 1/10 |
| LH-32150-16-3 | 32 | 150 | 16 | 1/5 |
| LH-32150-16-2 | 32 | 150 | 15.875 | MT#2 |

material(材質) : HB₃C₃

Mastech Trading Co., Ltd.

Electrode for Spot Welder

Offset Holder

φ 32 15° type

L型ホルダー φ32×15°

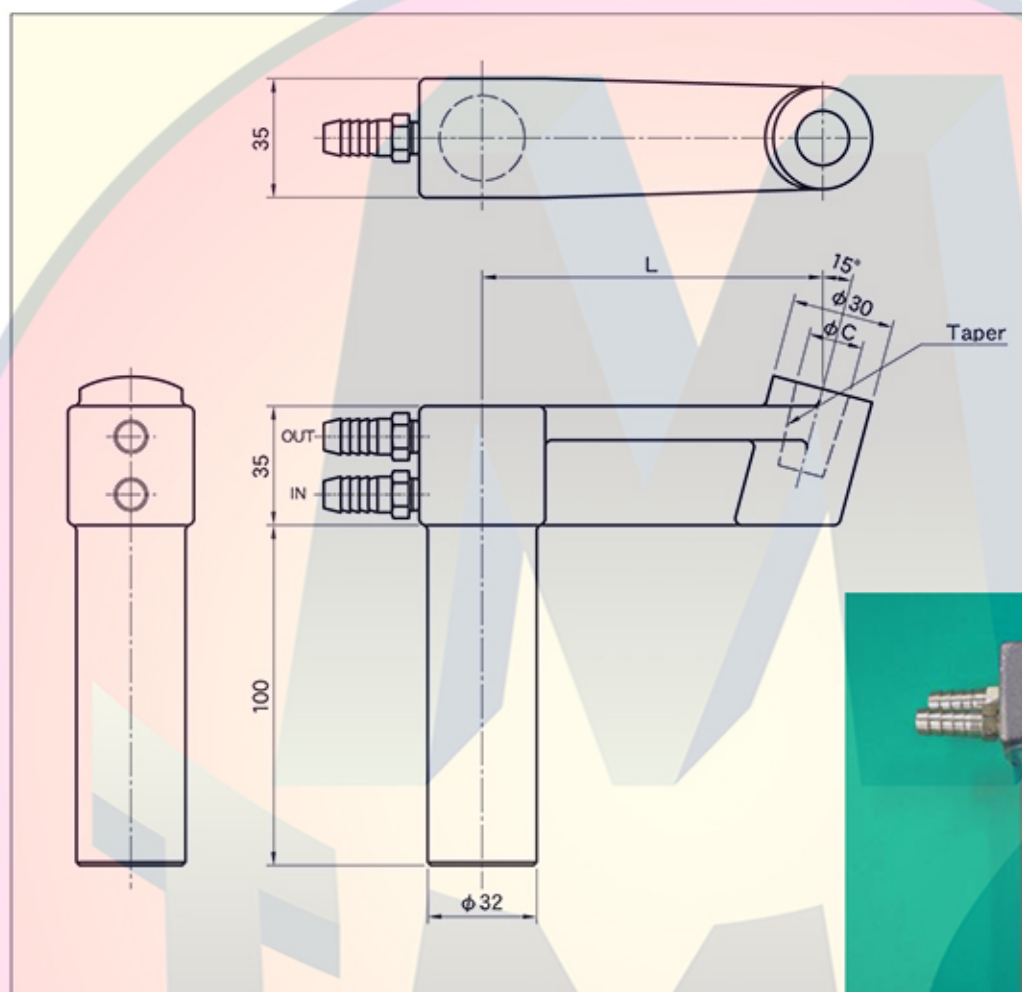

Unit(単位):mm

| Model No. 型式 | Dia 軸径φD | L ホルダー長 | OutsideDia チップ外径φC | TipTaper チップテーパ |
|-----------------|-------------|------------|-----------------------|--------------------|
| LH15-3250-16-1 | 32 | 50 | 16 | 1/10 |
| LH15-3250-16-3 | 32 | 50 | 16 | 1/5 |
| LH15-3250-16-2 | 32 | 50 | 15.875 | MT#2 |
| LH15-3270-16-1 | 32 | 70 | 16 | 1/10 |
| LH15-3270-16-3 | 32 | 70 | 16 | 1/5 |
| LH15-3270-16-2 | 32 | 70 | 15.875 | MT#2 |
| LH15-32100-16-1 | 32 | 100 | 16 | 1/10 |
| LH15-32100-16-3 | 32 | 100 | 16 | 1/5 |
| LH15-32100-16-2 | 32 | 100 | 15.875 | MT#2 |

material(材質): HB_sC₃

Offset Holder

L型ホルダー

Mastech Trading Co., Ltd.

Offset Holder for Cap Tips

L型ホルダー(キャップチップタイプ)

Offset Holder

L型ホルダー

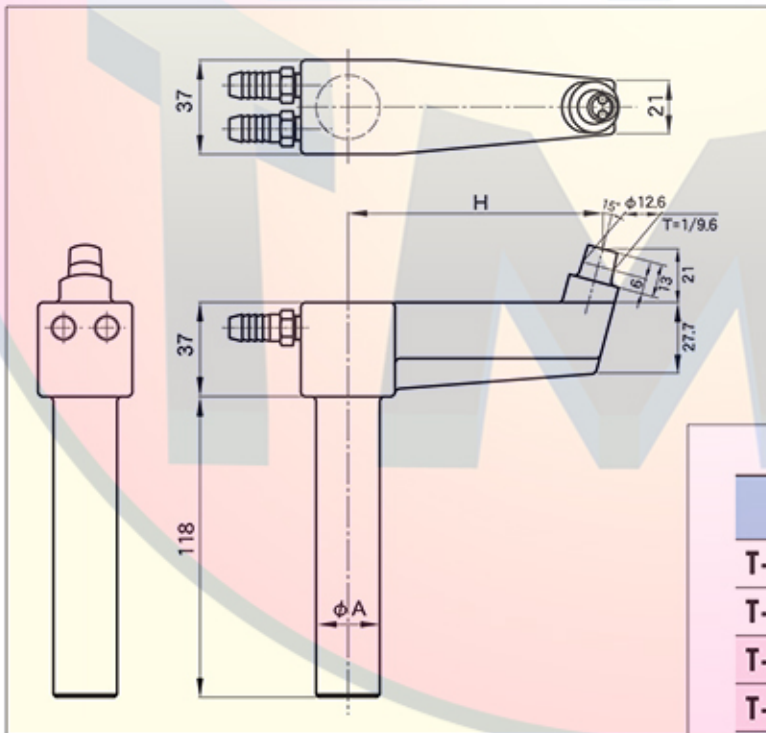
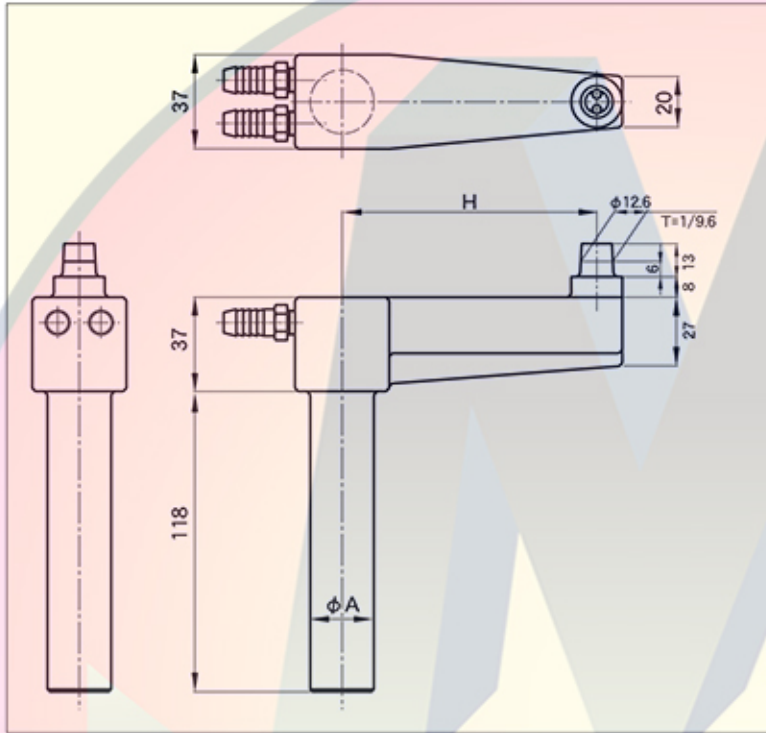

※We can make $\phi 12.7 \times 1/10$ taper too.
 ※テーパー $\phi 12.7 \times 1/10$ も製作します。

Unit(単位):mm

| Model No. 型式 | ϕA | H | θ° |
|-------------------------|----------|-----|----------------|
| T-CLL-25-70-90°-T1/9.6 | 25 | 70 | 90° |
| T-CLL-25-70-15°-T1/9.6 | 25 | 70 | 15° |
| T-CLL-32-70-90°-T1/9.6 | 32 | 70 | 90° |
| T-CLL-32-70-15°-T1/9.6 | 32 | 70 | 15° |
| T-CLL-25-100-90°-T1/9.6 | 25 | 100 | 90° |
| T-CLL-25-100-15°-T1/9.6 | 25 | 100 | 15° |
| T-CLL-32-100-90°-T1/9.6 | 32 | 100 | 90° |
| T-CLL-32-100-15°-T1/9.6 | 32 | 100 | 15° |

material(材質): HB₃C₃

Mastech Trading & Technology Ltd.

Ltype Holder with Bent Tip

曲がりチップ付ホルダー

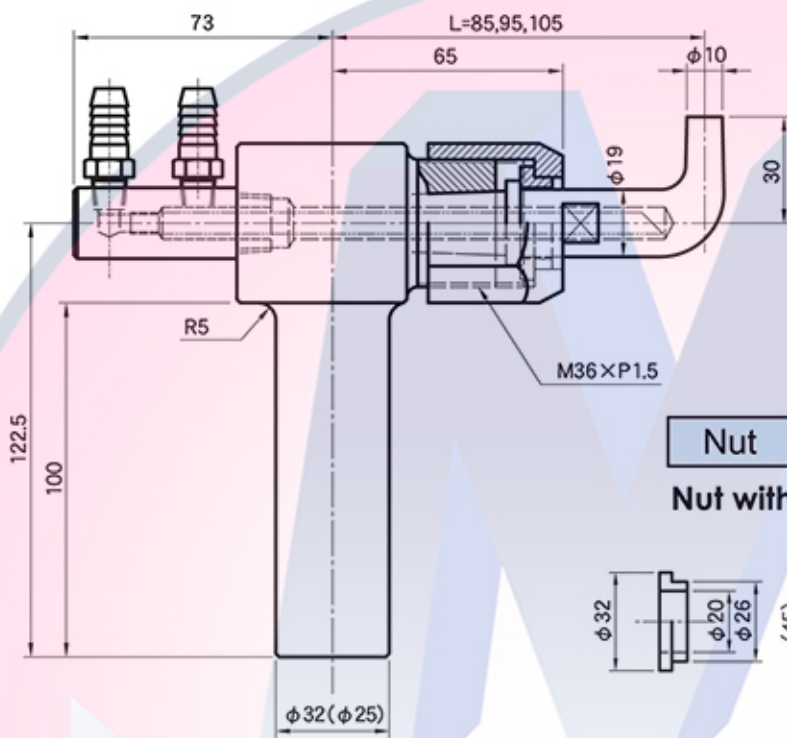

Nut **BNR-M3638**

Nut with Ring リング締付ナット

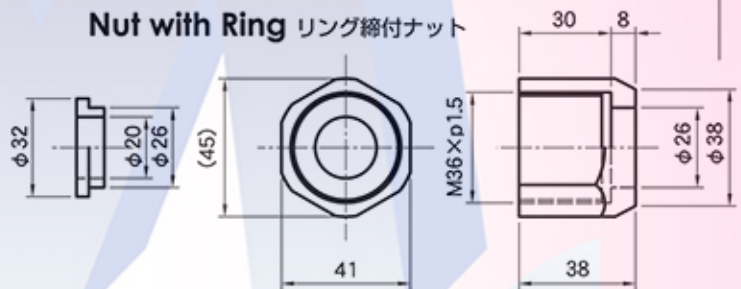

Unit(単位):mm

| Holder Assy Model No. 型式 | L | Bend tip No. チップ型式 |
|-----------------------------|------------|-----------------------|
| BH-32850 | 85 | BT-183085 |
| BH-32950 | 95 | BT-183095 |
| BH-32105 | 105 | BT-1830105 |

material(材質) : HB₅C₃

L=85 **BT-183085**

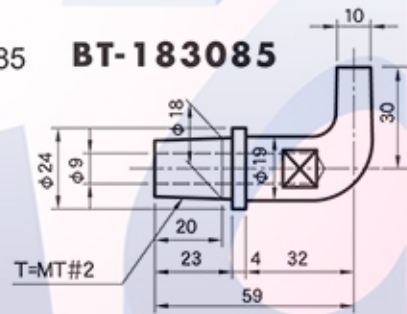

L=95 **BT-183095**

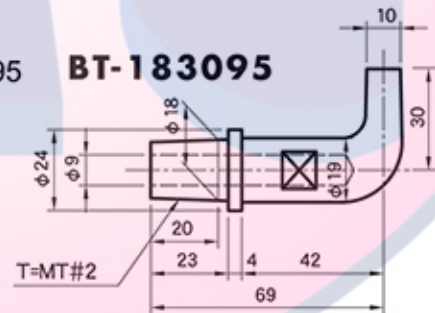

L=105 **BT-1830105**

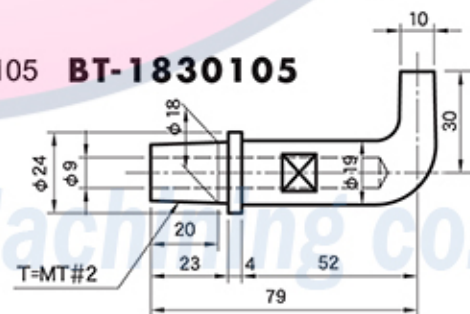

material(材質) : CrCu(クローム銅)

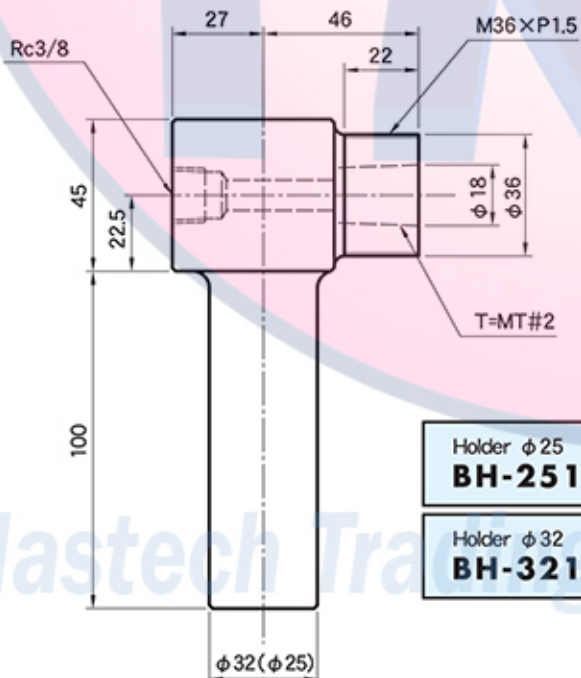

Holder φ25
BH-25100

Holder φ32
BH-32100

Mastech Trading & Machining Co., Ltd.

Ltype Holder

曲がりチップ付ホルダー

Lower Electrode for Tube Welding

円筒溶接用下部電極

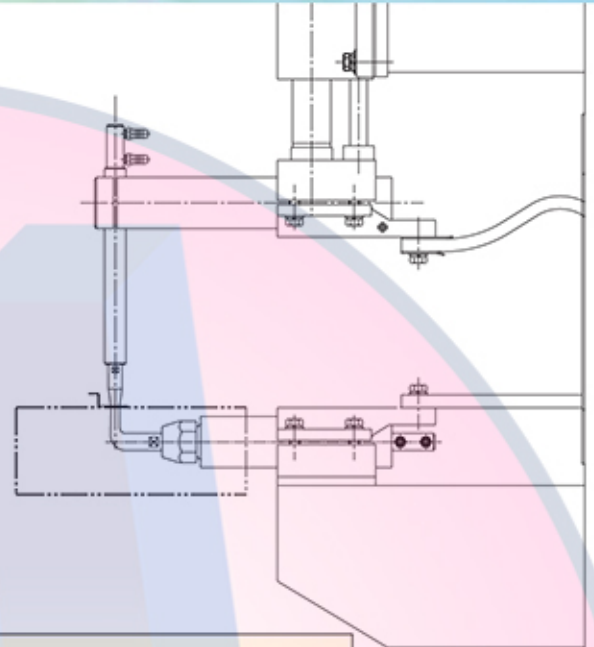
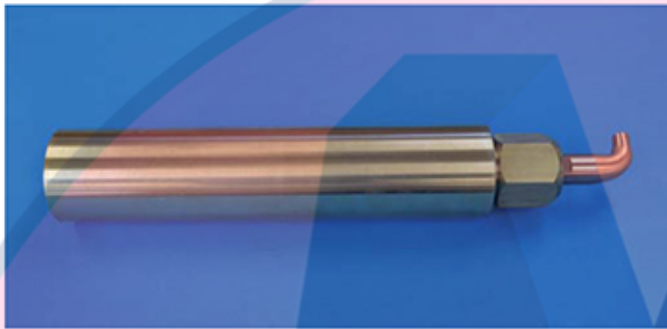

Dia ϕ Length(L) H
TW- [] - [] - []

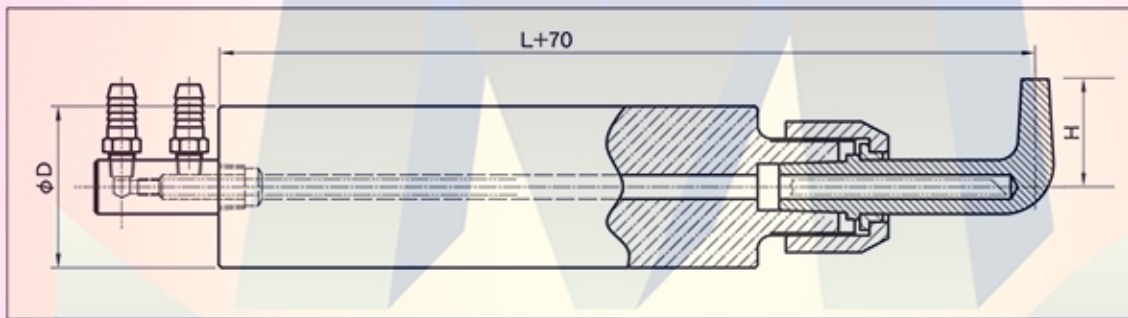

Dia ϕ Length(L)
Holder TW- [] - []

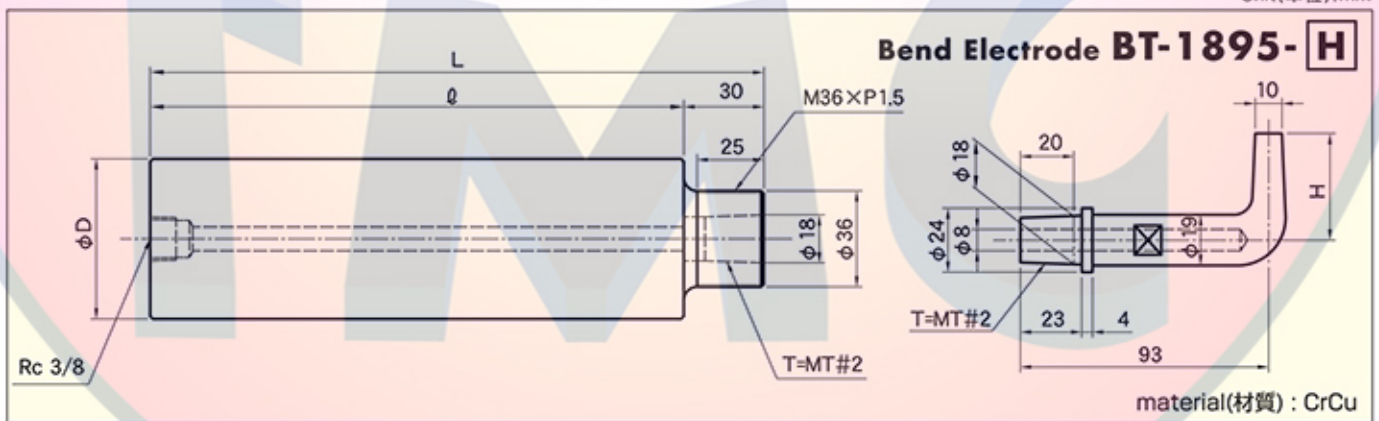

Unit(単位):mm

| Model No. 型式 | Outside Dia 外径 ϕ | Length 長さL | High 高さH |
|-----------------|--------------------------|---------------|-------------|
| TW-50230 | 50 | 230 | 30 |
| TW-55230 | 55 | 230 | 35 |
| TW-60230 | 60 | 230 | 40 |
| TW-50300 | 50 | 300 | 30 |
| TW-55300 | 55 | 300 | 35 |
| TW-60300 | 60 | 300 | 40 |

material(材質): B₅BM

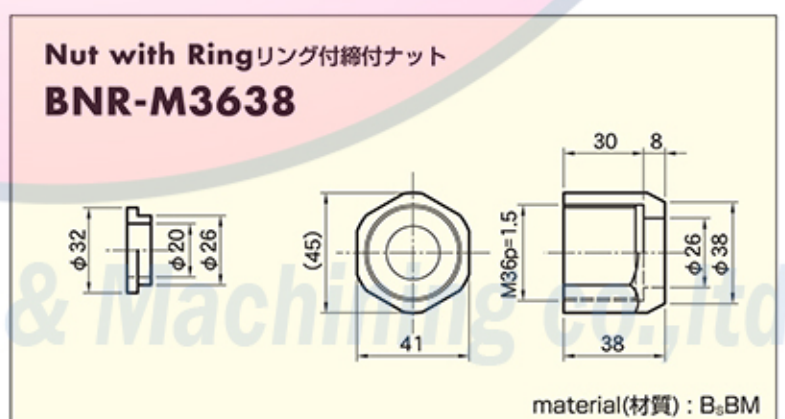

Lower Electrode for Tube welding

円筒溶接用下部電極

Ttype Electrode Holder for Tube Welding

T型ホルダー(スライドタイプ)

Unit(単位):mm

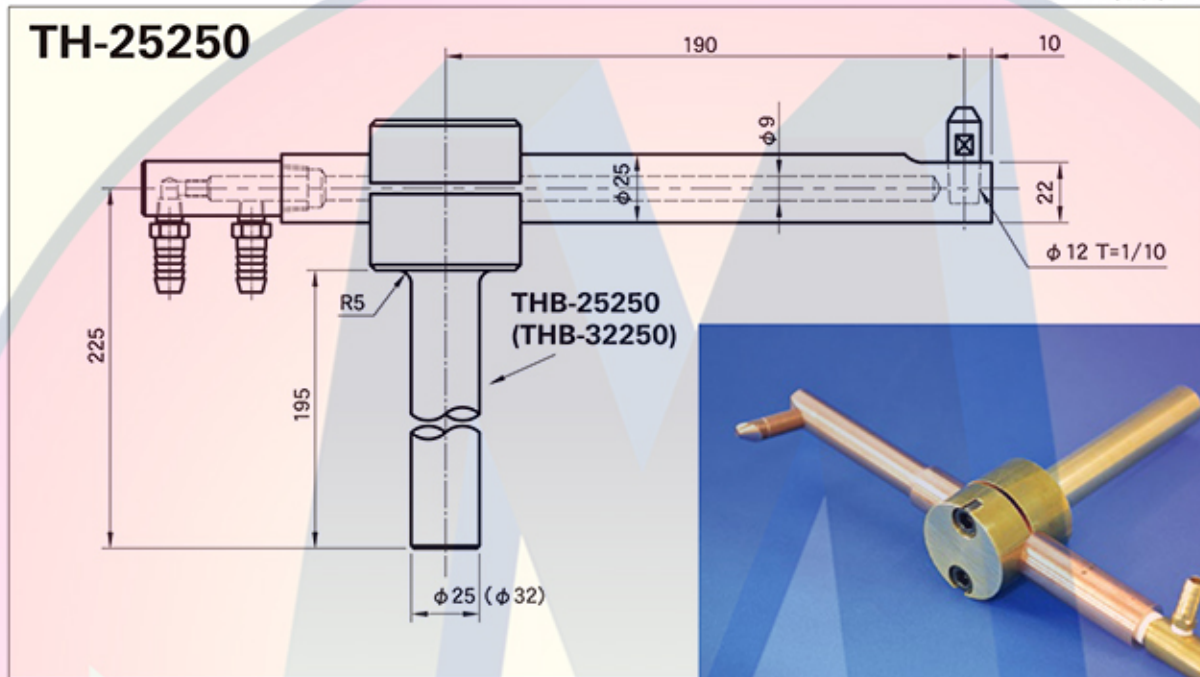

material(材質) : CrCu(クローム銅)

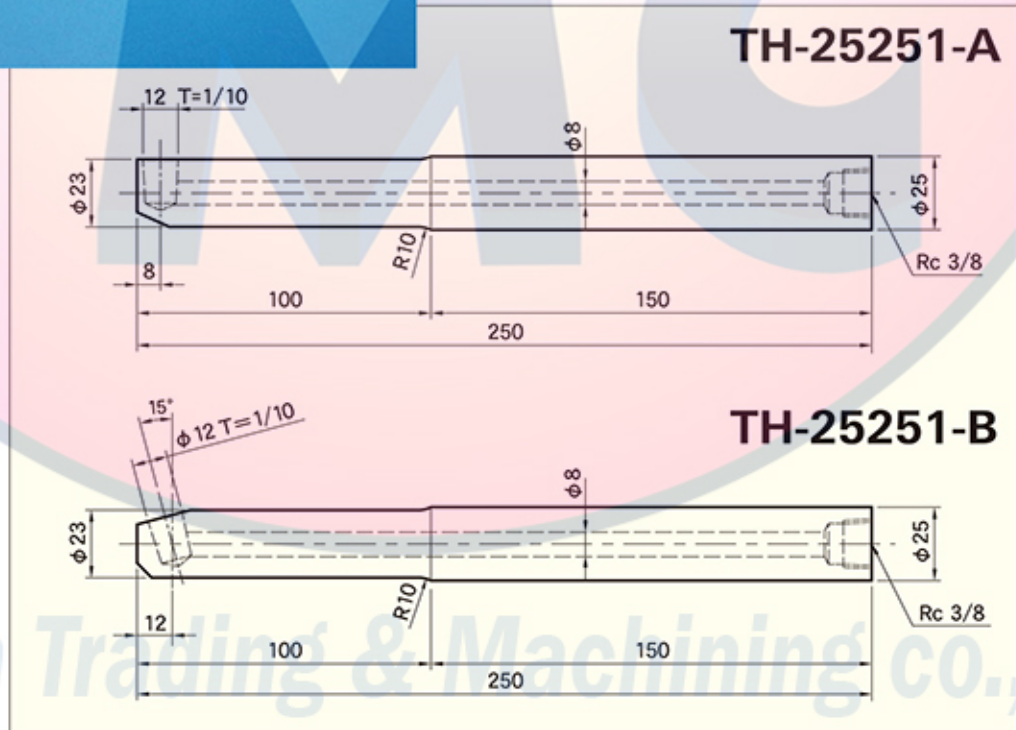

Mastech Trading & Machining Co., Ltd.

Ttype Electrode Holder (スライドタイプ)

Ttype Electrode Holder for Tube Welding

T型ホルダー(スライドタイプ) 90°タイプ

Bend Holder 90° type



material(材質) : CrCu(クローム銅)

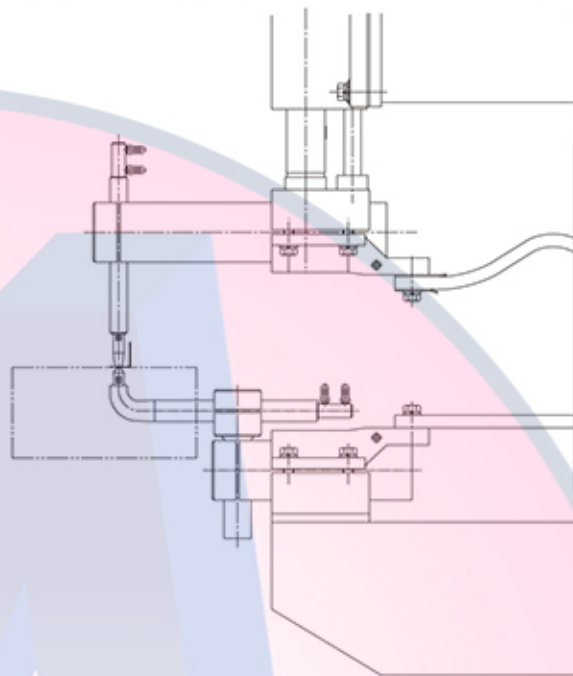

TB-25250-90° type

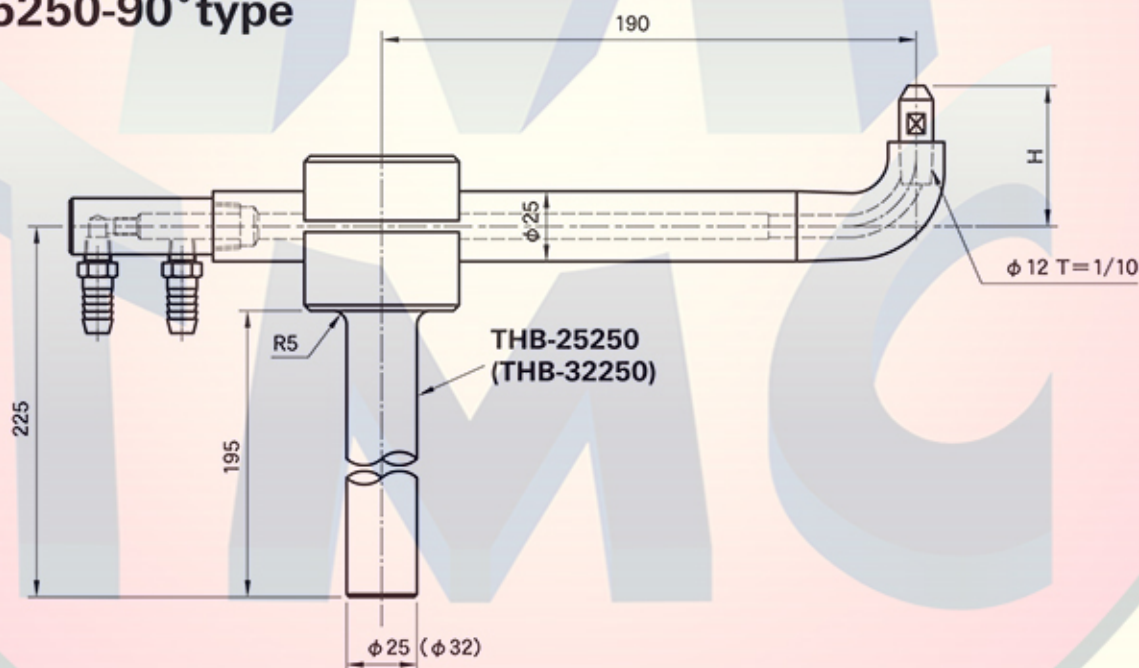

Bend Arm TB-25250-90-A

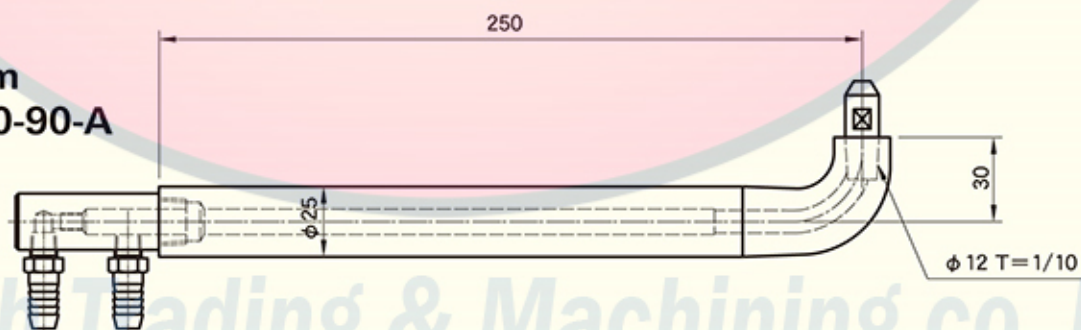

Mastech Trading & Machining co., Ltd.

Ttype Electrode Holder for Tube Welding

T型ホルダー(スライドタイプ)15°タイプ

Bend Holder 15° type

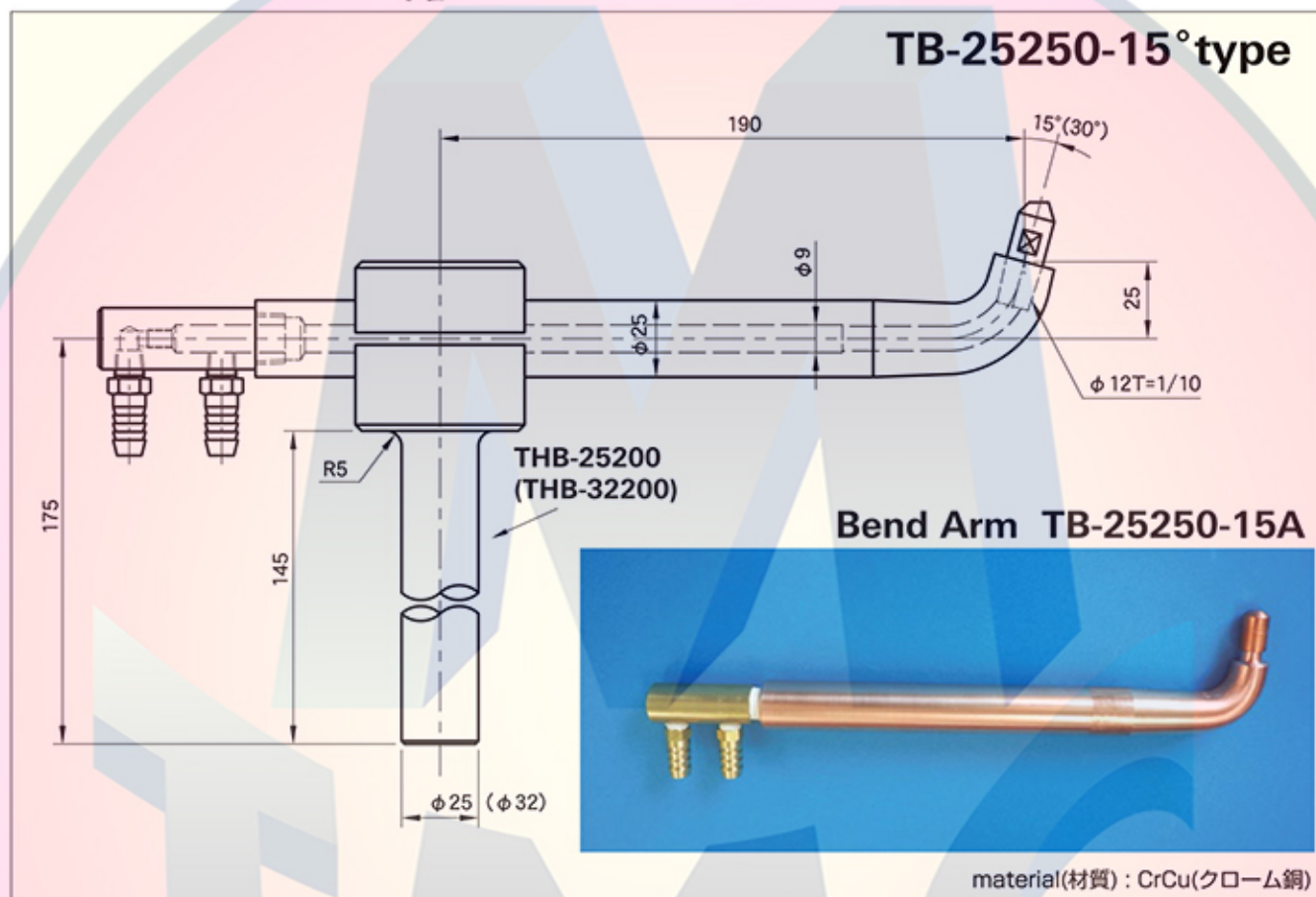

material(材質) : B₂BM

THB-25200
T型ホルダー本体

THB-32200
T型ホルダー本体

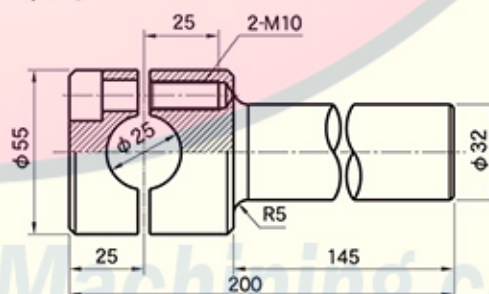
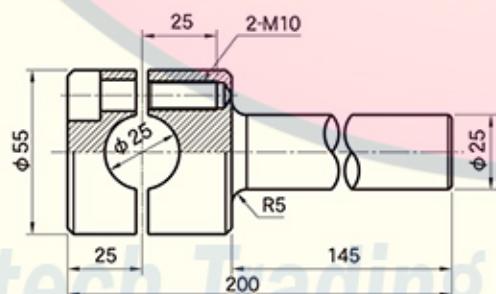

Arm for Spot Welder

BSホーン(φ50,φ55)

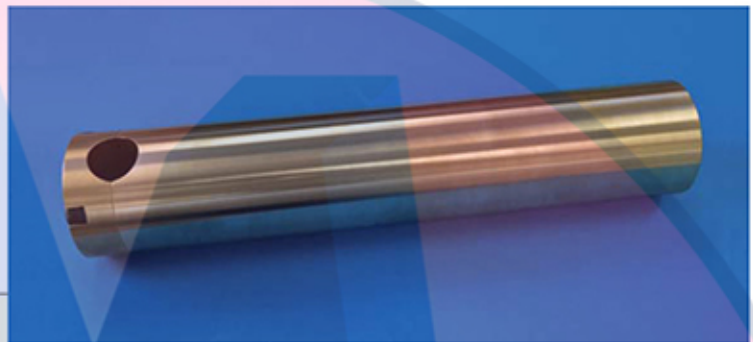

φ50

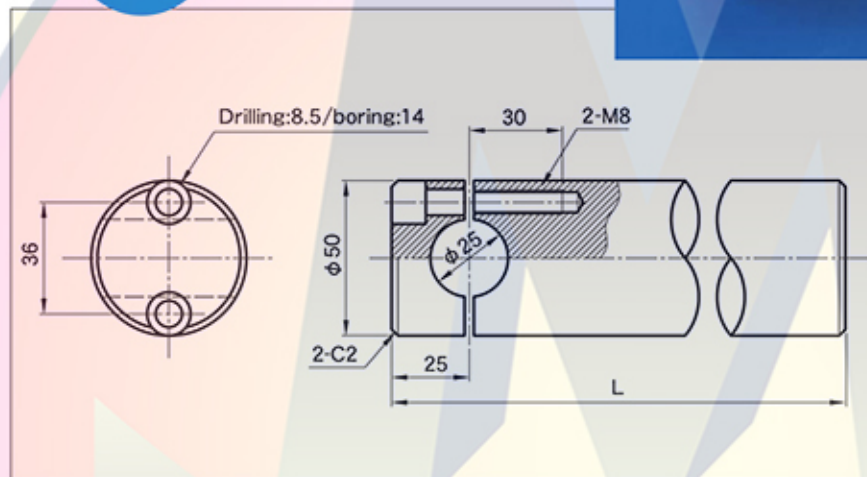

Unit(単位):mm

| Model No. 型式 | Outside Dia 外径φD | L 全長 |
|-----------------|---------------------|---------|
| TBH-5020 | φ50 | 200 |
| TBH-5025 | φ50 | 250 |
| TBH-5030 | φ50 | 300 |
| TBH-5040 | φ50 | 400 |
| TBH-5050 | φ50 | 500 |
| TBH-5060 | φ50 | 600 |

material(材質) : B_sBM

φ55

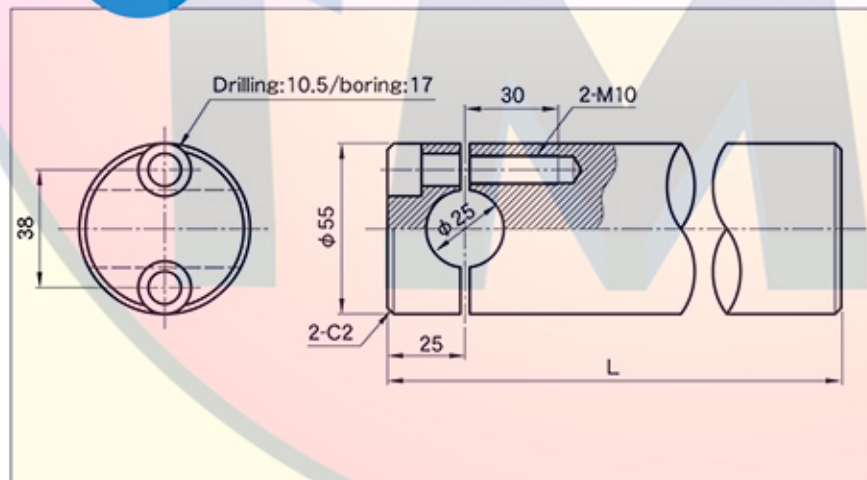

Unit(単位):mm

| Model No. 型式 | Outside Dia 外径φD | L 全長 |
|-----------------|---------------------|---------|
| TBH-5520 | φ55 | 200 |
| TBH-5525 | φ55 | 250 |
| TBH-5530 | φ55 | 300 |
| TBH-5535 | φ55 | 350 |
| TBH-5540 | φ55 | 400 |
| TBH-5545 | φ55 | 450 |
| TBH-5550 | φ55 | 500 |
| TBH-5560 | φ55 | 600 |

material(材質) : B_sBM

Arm for Spot Welder

BSホーン(φ60,φ70)

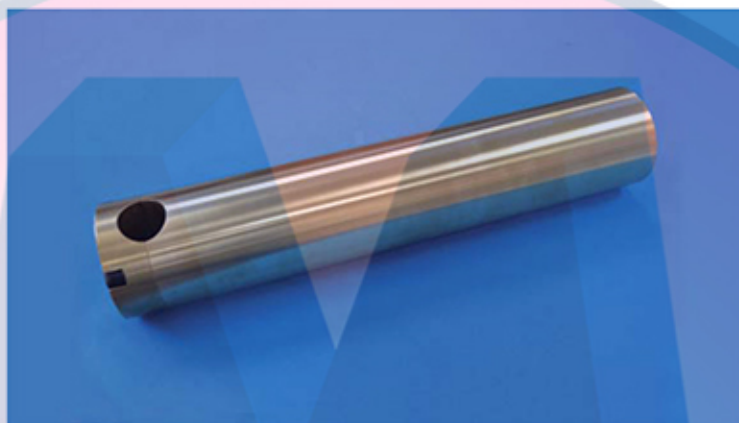

φ60

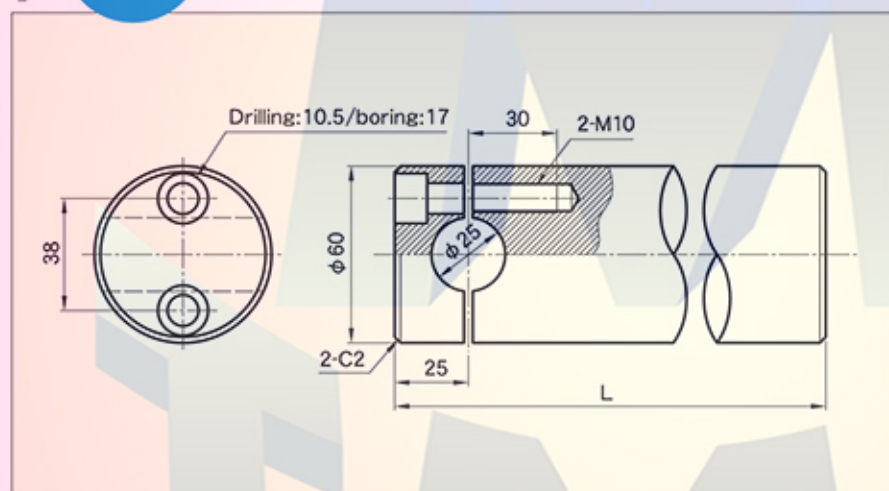

Unit(単位):mm

| Model No. 型式 | Outside Dia 外径φD | L 全長 |
|-----------------|---------------------|---------|
| TBH-6020 | φ60 | 200 |
| TBH-6025 | φ60 | 250 |
| TBH-6030 | φ60 | 300 |
| TBH-6035 | φ60 | 350 |
| TBH-6040 | φ60 | 400 |
| TBH-6050 | φ60 | 500 |
| TBH-6060 | φ60 | 600 |

material(材質): B_sBM

φ70

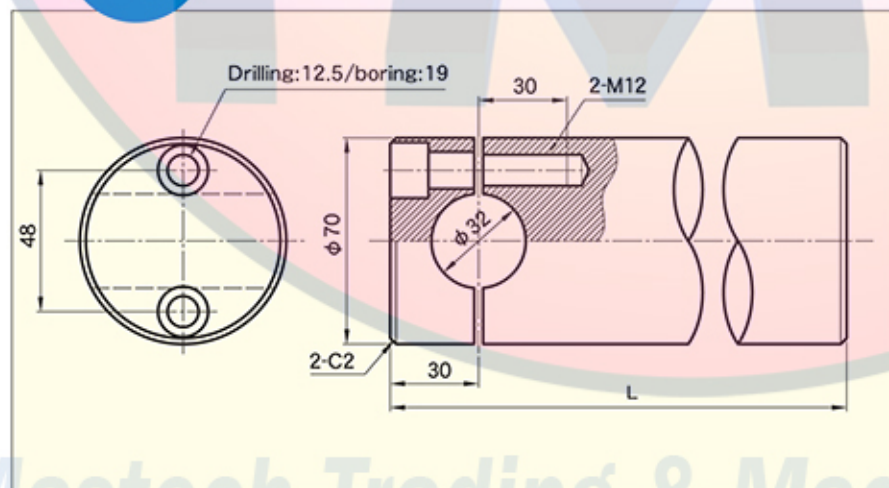

Unit(単位):mm

| Model No. 型式 | Outside Dia 外径φD | L 全長 |
|-----------------|---------------------|---------|
| TBH-7020 | φ70 | 200 |
| TBH-7025 | φ70 | 250 |
| TBH-7030 | φ70 | 300 |
| TBH-7035 | φ70 | 350 |
| TBH-7040 | φ70 | 400 |
| TBH-7050 | φ70 | 500 |
| TBH-7060 | φ70 | 600 |

material(材質): B_sBM

Mastech Trading & Machining Co., Ltd.

Arm for Spot Welder

BSホーン(φ80)

φ80

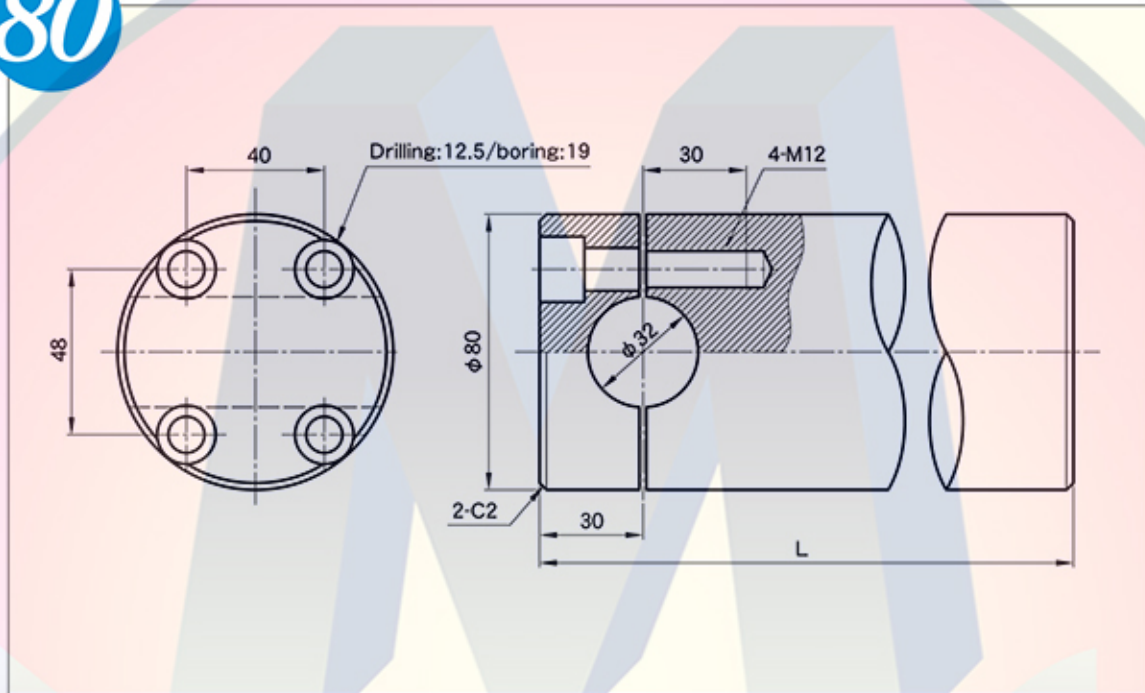

Unit(単位):mm

| Model No. 型式 | Outside Dia 外径φD | L 全長 |
|-----------------|---------------------|---------|
| TBH-8020 | φ80 | 200 |
| TBH-8025 | φ80 | 250 |
| TBH-8030 | φ80 | 300 |
| TBH-8035 | φ80 | 350 |
| TBH-8040 | φ80 | 400 |
| TBH-8050 | φ80 | 500 |
| TBH-8055 | φ80 | 550 |
| TBH-8060 | φ80 | 600 |

material(材質) : B2BM

