

# Insert Electrode

インサート電極

## Screw Insert Electrode

ネジインサート電極

Unit(単位):mm

Base Tip

ネジキノコチップ



Model No. 型名	φ d
W-BT-S-1	6
W-BT-S-2	8
W-BT-S-3	14

material(材質): CrCu(クローム銅)

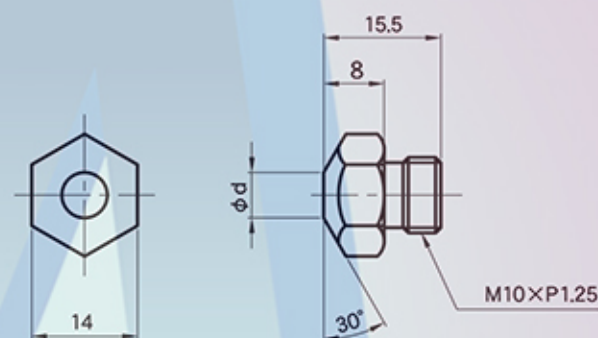

## Insert Electrode

インサート電極

Unit(単位):mm

19×38

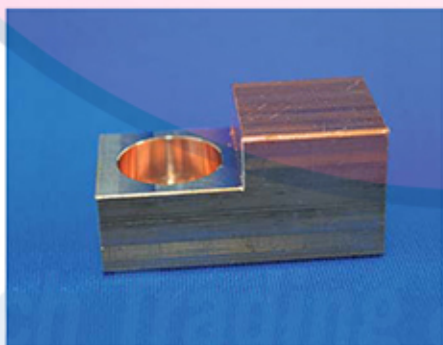
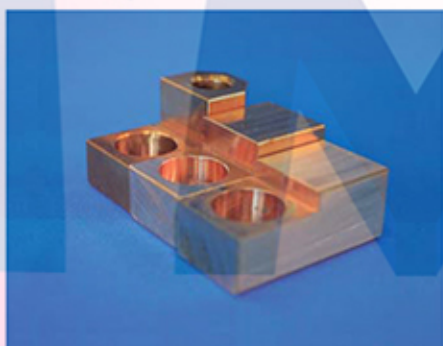

Model No. 型名	H
IN-19-16	16
IN-19-19	19

material(材質): CrCu(クローム銅)

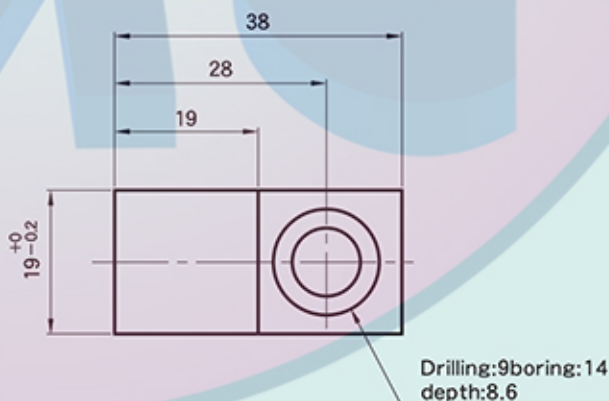

# Insert Electrode for Multiple Spot Welder

インサート電極

## W-IN-16S-19S

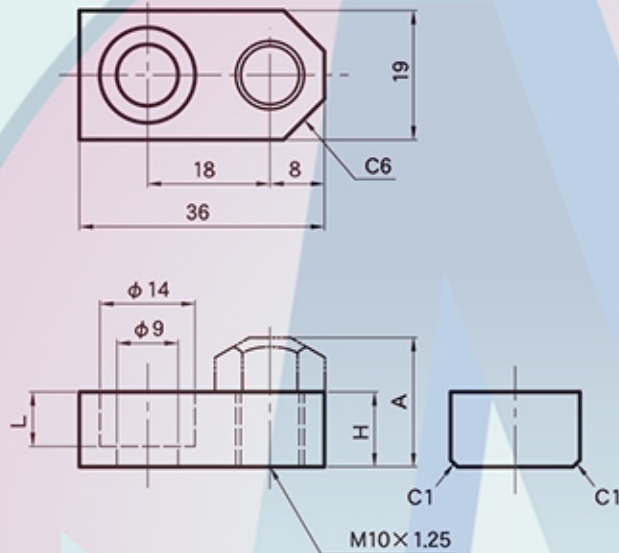

## W-IN-30-S

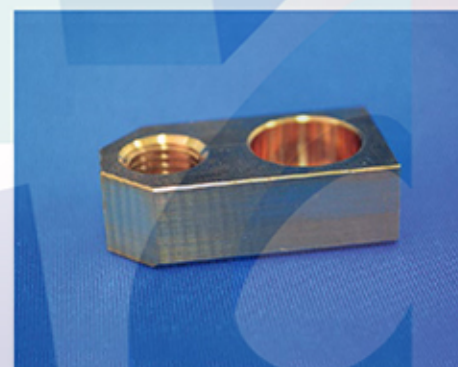
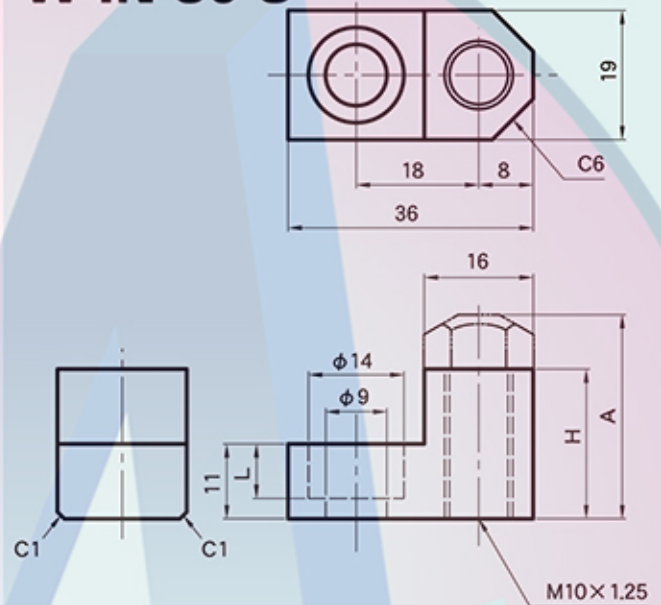

## W-IN--S

Effective length A  
有効長A

Please order with the model number on the left.  
ご注文は左記の記号にてお願いいたします。

Model No. 型式	H	L	Effective length A 有効長
W-IN-16-S	8	6	16
W-IN-19-S	11	8	19
W-IN-30-S	22	8	30

Unit(単位):mm  
material(材質): CrCu(クローム銅)

