

Seam Head

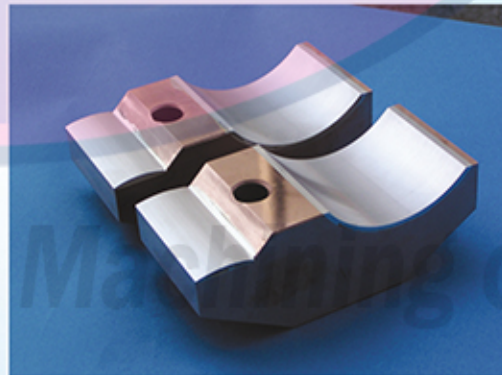

Overhaul for every manufacturer's seam head are acceptable.

1. Repair of rolling electrode shafts and current supply section of Brush.
2. Replacement of Bearings, Insulation parts and packings.
3. Replacement of Cooling water tube.
4. Adjustment of current supply section and try out.

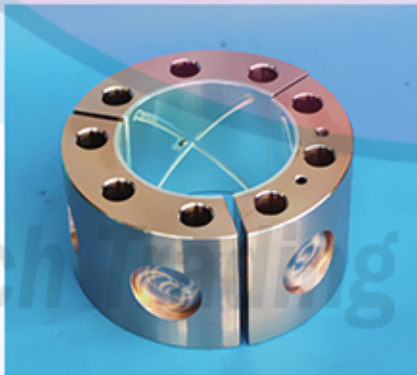

Brush for Seam Welding

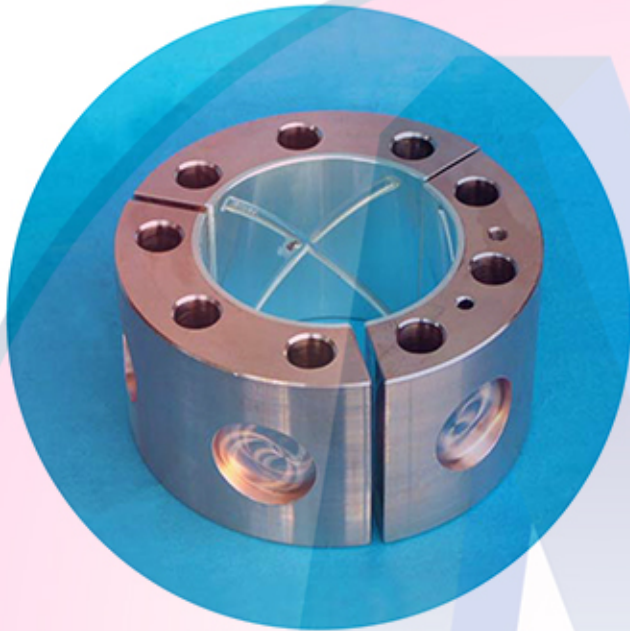

Material:Cu+Ag plate

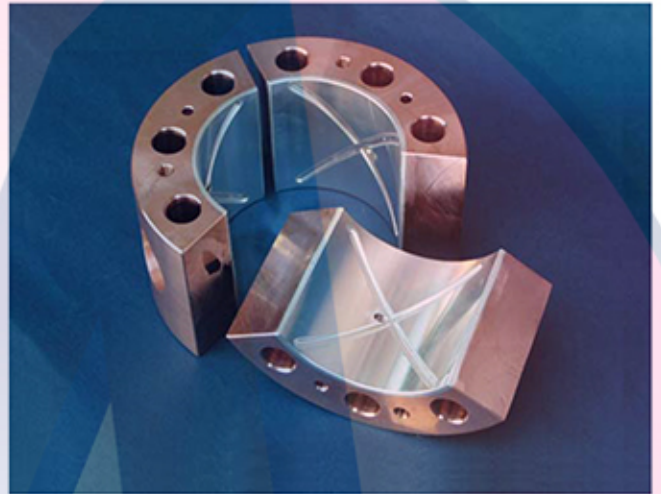

Current supply section of Brush is the section which is most deteriorated section by corrosion and abrasion.

In case of repair work by Saitama Yozai, it is sufficiently grinded after replacement of Silver plate and fully adjusted surface of grinding section.



刷子の給電面は電蝕や摩耗により劣化の激しい部分です。

埼玉溶材では修理の場合、銀板張替後の摺り合せを十分に行い、摺動部の面当たりを完全にしております。

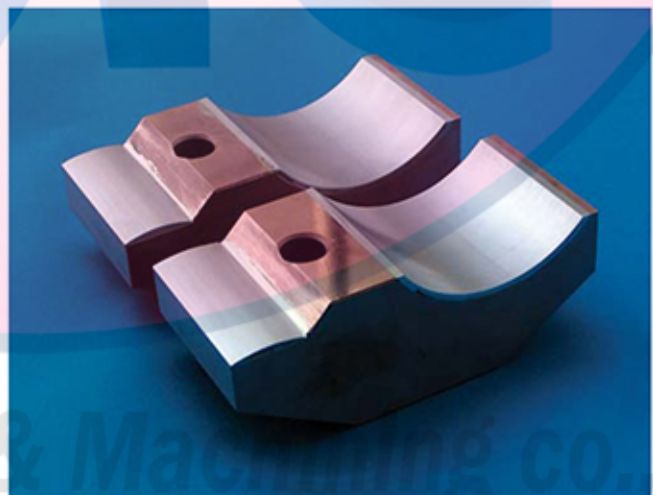

Please supply drawing or sample for manufacturing Brush.

Wheel Electrode for Seam Welding

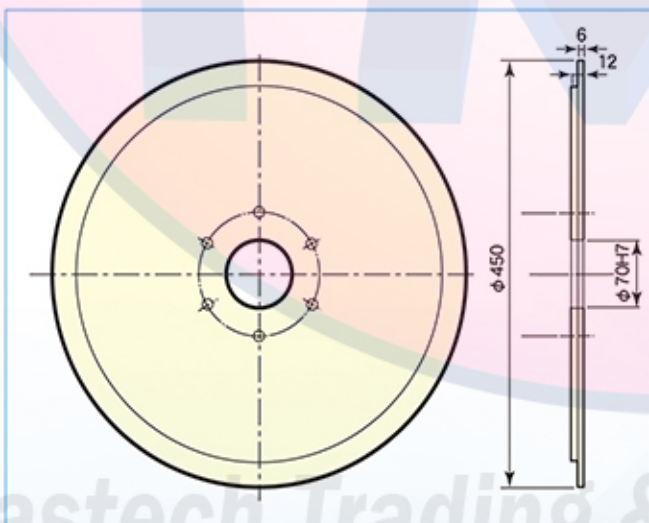
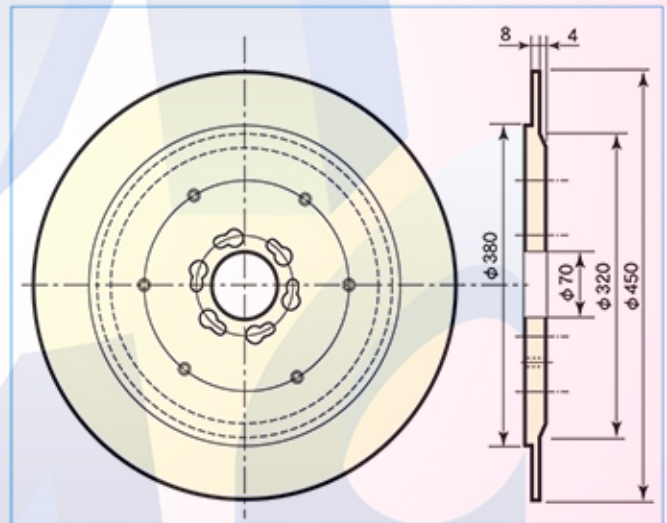
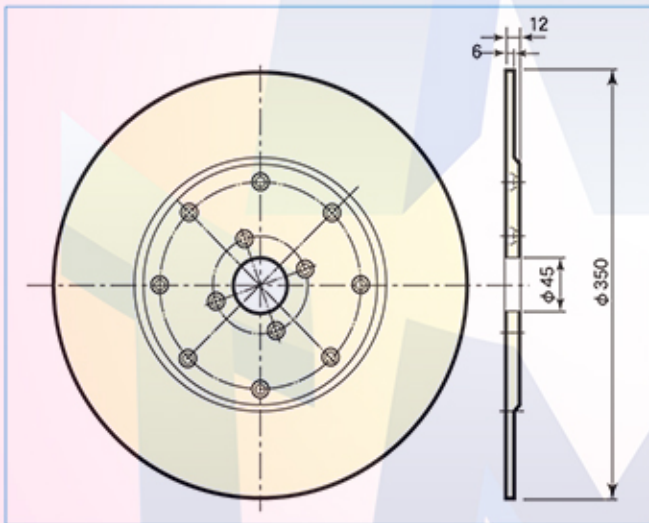
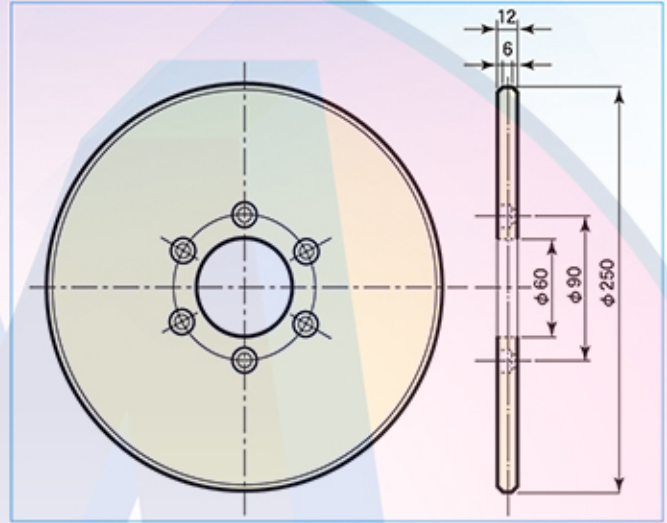

Mastech Trading & Machining Co., Ltd.

Please supply drawing or sample for manufacturing Wheel Electrode.